

Western Power Distribution Losses Strategy

February 2019

Table of Contents

Contents

1	Aims, Objectives and Outputs.....	6
1.1	Aims of this Document	6
1.2	Objectives	6
1.3	Outputs	6
2	Standard Conditions of the Electricity Dist. Licence.....	8
2.1	Part B: The Distribution Losses Strategy - Clause 49.4	8
2.2	Part B: The Distribution Losses Strategy - Clause 49.5	8
3	Stakeholder Input, Review and Governance	10
3.1	Stakeholder Engagement.....	10
3.2	Stakeholder Feedback	10
3.3	Losses Strategy Review	10
3.4	Losses Strategy Governance.....	11
4	Innovations and Projects.....	12
4.1	SOHN Associates Losses Report	12
4.2	LV Templates	12
4.3	Losses Investigation.....	13
4.4	FALCON.....	15
4.5	EQUILIBRIUM	15
4.6	Industrial & Commercial Storage Project.....	17
5	Background and Theory.....	20
5.1	Reasons for Reducing Losses.....	20
5.2	What are Losses?	20
5.3	Technical Losses	21
5.3.1	Fixed Losses	21
5.3.2	Variable Losses	22
5.3.3	Phase Imbalance.....	23
5.3.4	Power Factor.....	24
5.3.5	Harmonics	24
5.3.6	11kV Network Optimisation	25
5.3.7	Network Meshing.....	26
5.3.8	Demand side response	27
5.3.9	Virtual Private Wire	27
5.4	Non-technical Losses.....	27
5.4.1	Unmetered Supplies	27
5.4.2	Theft in Conveyance.....	28
5.5	Distributed Generation and DSO.....	28
5.6	Which Parts of the Network Produce the Most Losses	29
6	Improving Understanding.....	30
6.1	Quantifying and Monitoring	30
6.2	Smart-meters.....	31
	Computational Modelling	31
		6.3 31

6.4	Harmonics	32
6.5	Asset Replacement	32
7	Policies and Actions.....	33
7.1	Assessment	33
7.2	Actions Completed Before 2018.....	33
7.2.1	Cable Tapering	33
7.2.2	Cable Sizes	33
7.2.3	Transformers.....	34
7.2.4	Reducing Cable Lengths.....	35
7.2.5	Voltage Reduction.....	35
7.3	Actions Completed During 2018 and ongoing actions.....	36
7.3.1	Asset Replacement.....	36
7.3.2	Network Design and Policy review	36
7.3.3	Stakeholder Engagement	37
7.3.4	Losses pages on WPD website	37
7.3.5	Revenue Protection - Supplier Side Abstraction	37
7.3.6	Revenue Protection - Unmetered Supplies.....	38
7.3.7	Revenue Protection - Theft in Conveyance	38
7.3.8	ENA Losses Group	39
7.4	Plans for 2019 and beyond	39
7.4.1	EV's and Streetlights	41
7.4.2	Automatic LV Mains Phase Imbalance Correction	41
7.4.3	11kV Network Optimisation	41
7.4.4	Three Phase LV Service Cables.....	41
7.4.5	Desktop Studies of the LV network and customer connections	42
7.4.6	Legacy network conversions	42
7.4.7	Substation Footprint.....	43
7.4.8	Car Park Charging	43
8	Future Considerations	44
8.1	Superconductors.....	44
8.2	Heat Recovery.....	44
8.3	Active network configuration for losses.....	45
9	Summary & Conclusions.....	47
9.1	Summary	47
9.2	Assessment of our Losses Performance	48
9.3	Plans for 2019/2020	48
9.4	Table of Outputs.....	48
	Appendix 1: Progress on SOHN Recommendations.....	49
	Bibliography.....	55

Glossary

Abbreviation	Term
A	Ampere
ac	alternating current
Al	Aluminium
BAU	Business As Usual
CBA	cost-benefit analyses
CSE	Centre for Sustainable Energy
CT	Current Transformer
Cu	Copper
DC	Direct Current
DINIS	Distribution Network Information System
DSR	Demand Side Response
DNO	Distribution Network Operator
DSO	Distribution System Operator
ENA	Electricity Networks Association
ES	Energy storage (battery)
EU	European Union
EV	Electric Vehicle
EVA	Enhanced Voltage Assessment
EHV	33kV and up to and including 132kV (WPD standard)
FCL	Fault Current Limiter
FPL	Flexible Power Link
GWh	Giga Watt hour
HH	Half hourly
HV	11kV (WPD standard)
IIS	Interruptions Incentive Scheme
IPSA	Independent Power System Analysis
IPC	Insulation piercing connector
kVA	Kilo Volt Ampere
kW	Kilo Watt
kWh	Kilo Watt hour
LCNF	Low Carbon Network Fund

Abbreviation	Term
LCT's	Low Carbon Technologies
LDB's	Link Disconnecting Boxes
LEAN	Low Energy Automated Networks
LV	240/400V Low Voltage
m	million
MPAN	Meter point administration number
MV	Medium Voltage
MVA	Mega Volt Ampere
MWh	Mega Watt hour
NIA	Network Innovation Allowance
NOP's	Normal Open Points
PSSE	Power System Simulation and Engineering
PV	Photo Voltaic (Solar)
RIIO-ED1	Revenue = Incentives + Innovation + Outputs – Electricity Distribution 1
RIIO-ED2	Revenue = Incentives + Innovation + Outputs – Electricity Distribution 2
SCADA	System control and data acquisition
SMETS 1	Smart Metering Equipment Technical Specification first version
SMETS 2	Smart Metering Equipment Technical Specification second version
SVO	System Voltage Optimisation
TASS	Transformer Auto Stop Start
TDH	Total Harmonic Distortion
UGC	Underground cable
UK	United Kingdom
UKPN	United Kingdom Power Networks
UKRPA	UK Revenue Protection Agency
UMS	Unmetered supply
UPRN	Unique property reference
WPD	Western Power Distribution
WSP	Engineering Consultants

1 Aims, Objectives and Outputs

1.1 Aims of this Document

The intention of this document is to provide an outline of the actions that are being taken by Western Power Distribution in order to reduce losses. The Introduction and Theory section provides a basic explanation of losses on distribution networks. A comprehensive list of the actions that are being taken to reduce losses can be found in the Policies and Actions section and summarised in the Table of Outputs. Much of the WPD strategy is based around the recommendations produced by SOHN Associates in their 'Management of Electricity Distribution Network Losses' report which is attached in Appendix [1]. These recommendations are referenced throughout the report. This year WPD has included items from the ENA Technical Losses Working Group, including research completed by the Engineering Consultants WSP. The document, in addition has extended its focus to take into account future changing demands on the electricity network as a result of the introduction of Low Carbon Technologies (LCT's) and the UK Governments Road to Zero Strategy.

1.2 Objectives

WPD's objectives regarding losses management are that by the end of the RIIO- ED1 period:-

- The losses across the WPD network will have been reduced to a level that is as low as economically and practically viable;
- All future investment decisions will take losses into account to ensure that the best balance is achieved between network investment costs today and energy supply costs for future customers;
- Providing the SMETS 2 smart-meter data is available, WPD will have the tools and methods in place to accurately locate the points on the network with particularly high losses;
- All of the WPD stakeholders will be aware of the importance of losses; and
- Using the knowledge gained from various innovation projects, computer modelling and investment appraisal WPD will through BAU have produced new and effective means to reduce losses;

1.3 Outputs

During RIIO-ED1 WPD are undertaking: -

- The pro-active replacement of 1,996 distribution transformers;
- Purchase and installation of 88 single phase 25kVA 11kV amorphous transformers;
- The oversizing of 448 ground-mounted transformers and 575 pole-mounted transformers per annum;
- The design intervention for losses on new installation of 8,184 distribution transformers and 11,880 kilometres of underground cables;
- The discontinuation of cable tapering on all LV Mains cables and service cables;

- The identification of units lost to supplier side abstraction, unmetered supplies and theft in conveyance;
- A comprehensive programme of stakeholder engagement including biennial stakeholder consultation events;
- A comprehensive review of the WPD policies to ensure losses are a priority consideration for all the investment decisions;

2 Standard Conditions of the Electricity Dist. Licence

2.1 Part B: The Distribution Losses Strategy - Clause 49.4

WPD's Losses Strategy has been reviewed and modified to ensure that it provides economically beneficial interventions that will help keep distribution losses as low as reasonably practicable. The CBA's used in this version of the Losses Strategy are based on current WPD cost models and use the current Ofgem valuation of losses.

2.2 Part B: The Distribution Losses Strategy - Clause 49.5

A copy of this Losses Strategy document is available externally on the WPD website: -

<https://www.westernpower.co.uk/About-us/Innovation-Low-Carbon/Losses.aspx>

During the RIIO-ED1 period WPD plan to work through the recommendations of the 'Management of Electricity Distribution Network Losses' report (listed in Appendix 1 on page 43). Since the last version of the WPD Losses Strategy in February 2018, WPD has updated the Losses Strategy to include the recommendations considered during the past 12 months.

WPD's Losses Strategy document has undergone considerable restructuring, to make the document easier to read and navigate. A number of sections have been added, to provide more detail on certain areas. All of the WPD policies on losses and the actions WPD is taking have been compiled into a single section, titled 'Policies and Actions.'

This year will see WPD continue with their Losses Strategy, of the replacement of pre 1958 transformers, tapering of LV and 11kV circuits is no longer permitted, i.e. the use of 95mm² Al. LV mains and 11kV cables is no longer permitted, being business as usual. WPD is looking to new and innovative areas to reduce losses, to this end WPD are working with Pobl and Sero Homes to build circa 250 new homes fitted with PV, ES, HP and EV charging, these homes will be supplied via three phase service cables and dark fibre to each house, WPD will be fully monitoring the 11kV LV Mains feeders and each home to replicate the Isle of Man Losses Investigation which was looking at single phase LV services. What WPD are envisaging is a reduction of losses in the LV services cables, LV Mains cables and in the 11/0.4kV unit substation supplying the housing estate. It is envisaged that use of three phase service cables will reduce out of balance loads in the LV mains cables and on the 11/0.4kV transformer. In addition WPD is taking the governments Road to Zero Strategy to reduce the overall carbon emissions and by using the new build and retrofit projects gain knowledge on the modelling and all the effects PV, ES, HP and electric vehicle charging will have on the LV and 11kV networks.

Vehicle charging is likely to be the first major low carbon technology demand to be seen on the low voltage network, which has to be accommodated as a result of the Governments

introduction of updated Building Performance Regulations of April 2018. WPD are currently working with a number of Local Councils with a view to creating charging hubs using low loss padmount transformers, in addition working with councils to meet their clean air objectives. WPD's losses strategy plans will be completed alongside the normal business as usual.

An area where WPD have been lacking in the past is addressing losses on single phase 11/0.4kV transformers, this area is now being addressed, WPD has purchased 88 25kVA single phase amorphous transformers. Single phase transformers are outside of the Eco design transformer legislation, the transformer that have been purchased have Iron losses of 16W compared to the current CRGO transformer Iron losses of 65W.

3 Stakeholder Input, Review and Governance

3.1 Stakeholder Engagement

Stakeholder engagement is a key priority for WPD and, as loss reduction is effectively a new subject for many of stakeholders, it is important stakeholders are encouraged to engage with WPD on the topic. WPD's aim is to improve stakeholder's awareness of losses so that they can take steps to reduce losses themselves. This formed part of the general stakeholder engagement sessions held by WPD in 2014, from which WPD developed specific losses stakeholder engagement events. These events enable WPD to keep stakeholders informed of WPD's progress but also provide an opportunity for WPD to gather feedback on adopted approach, take on board new ideas, and potentially stimulate the development of new technology from manufacturers offering products that may assist WPD to reduce losses.

WPD has held three consultation events on losses: the first in November 2014, the second in November 2015 and the last one in November 2017. These events were targeted at stakeholders who would be likely to have a specific interest in losses, such as other DNO's, manufacturers and academics. Each event had a range of presentations from WPD on losses, discussing the basic issues of losses; the actions that were being taken and results from the ongoing innovation projects. The stakeholders were then given the opportunity to put forward their thoughts and provide feedback on the losses strategy to WPD.

Loss reduction activities are described in detail in the section 7.

3.2 Stakeholder Feedback

The majority of the feedback received at the last consultation was positive and stakeholders were pleased that WPD were heading in the right direction, so they were happy for WPD to continue working as they are. As a result of the discussions, suggestions were made for specific actions that should be taken. New subject areas such as the impact of EV's and future LCT effects that will have on the network have been added to the losses strategy.

3.3 Losses Strategy Review

The WPD losses strategy is reviewed on an annual basis and stakeholder consultation events will occur biennially. This frequency of review is supported by the stakeholders. WPD has a range of LCNF and NIA projects that are ongoing which are continuing to provide important new insights. Each year WPD will develop and act on the strategies targeted in SOHN document, obtain new information from the innovation projects, construct new strategies (which may be based on the results of the innovation projects) and then record the progress in the next strategy document.

The intention is both to review what has been done in the previous year and plan what is intended to do in the coming year and update the strategy accordingly.

3.4 Losses Strategy Governance

The WPD losses strategy is developed within the Network Strategy and Innovation Team and is approved by the CEO. Within this governance, the Network Strategy and Innovation Manager is responsible for the development of topics to address from the SOHN “Management of electricity distribution network losses” report. Each year the recommendations from this report are developed into areas for investigation. During the RIIO-ED1 period WPD will address each of the recommendations and plan to develop at least one technical and one non-technical recommendation per year. Appendix 1 shows plans for each recommendation and a justification for the WPD assessment of each plan.

4 Innovations and Projects

Innovation projects are the main way in which new methods can be developed to reduce losses, which is why they are a cornerstone of the losses strategy. Many of the projects have a focus on network monitoring and automated control, aiming to flatten load profiles. WPD is also looking at developments such as energy storage and heat recovery.

4.1 SOHN Associates Losses Report

The SOHN losses report [1] was commissioned by WPD and UKPN to provide an assessment of all the ways in which losses could be reduced. The report was written in partnership by SOHN Associates and Imperial College London, to provide an academic viewpoint on the range of the problem. The scope of the investigation was very broad, as the intention was to come up with as many potential solutions to reducing losses as possible. Using a network modelling tool designed by Imperial College and intelligent forecasting for future demand, potential approaches to reducing losses were identified. The report looked at possibilities such as heat recovery; active network management and asset replacement. These possible approaches led to 26 recommendations for DNO's to consider. These recommendations have formed the basis of the WPD losses strategies and all will be considered during the course of RIIO-ED1.

4.2 LV Templates

The LV Templates project [3] set up a highly monitored network in South Wales, to see if it was possible to characterise substations into a number of 'templates' which could be used to describe the temporal load and voltage behaviour of substations nationwide. The areas chosen for monitoring had dense populations of LCT's. This was to enable scaling up to represent the UK as a whole. The project found that around 82% of UK substations fitted one of ten district templates identified in this project.

The project also provided data on the voltages seen on the LV network. It concluded that there is scope to reduce the network voltage and remain within the statutory voltage parameters. Reducing the voltage will reduce the overall demand and makes a contribution to loss reduction. The voltage on the LV network can be reduced in many ways but WPD has chosen to change the settings at the primary substation level. At this point on the network, the voltage change can be made automatically without interrupting customers. WPD has completed a programme of voltage reduction in the South Wales area, and results have shown that a 0.88% reduction in primary voltage resulted in an average demand drop of 1.16%. As a result of this, losses increased in percentage terms but this is because the current has to be slightly higher to deliver the same power, which increases the variable loss, but the power required is lower, therefore overall losses are reduced. Based on these results, WPD has now commenced a programme of voltage reduction across all the WPD licence areas, the current status is, 1403 completed substations and 714 outstanding substations, with a target completion date of 2020.

4.3 Losses Investigation

Data relating to the power consumed by all individual connections on an LV cable or network was not included in the LV Templates monitoring, which was set up to measure the overall profile of a distribution substation.

Through a field-work programme, for HV feeders, one minute resolution logging equipment is being installed at the Primary Substation on the source breakers of the sample feeders, and at each load connection point along the feeder. This provides comprehensive information about actual power flows for a complete HV feeder, allowing actual losses to be assessed for a specific feeder.

For LV feeders, one minute resolution logging equipment has been installed at Distribution Substations, monitoring the entry/exit of power onto LV feeders; and one minute data is being logged at all connection points along the sample LV feeders. As with HV feeders, this instrumentation provides comprehensive information about power flows for a complete LV feeder, and allows actual LV losses to be assessed for a specific feeder. The LV field work was carried out on the Isle of Man in collaboration with Manx Utility Authority, as WPD are not allowed access to individual customer data in their own regions.

The Losses Investigation report is now nearing completion and final reporting. The HV estimation process is fully developed and has been demonstrated internally using HV feeders in the East Midlands Region. The LV estimation process is now well developed, with refinements underway associated with the demand model. All work on the project is now due for completion by the end of January 2019, with project reporting and dissemination being complete by end of April 2019.

With development of the HV feeder loss estimation process now complete, feeder-specific annual mean loss estimates have been generated for 2130 feeders in the East Midlands region of WPD. Details of findings and learning for the HV loss estimation work are available in the latest six month project progress report, with key items including: -

- **Method** - for each HV feeder, the loss estimation method combines network topology data with demand data in order to run a power-flow analysis from which the individual feeder losses are calculated. These individual feeder results are then collated so that loss characteristics of the overall HV feeder set can be examined and identified. An outline of the method is shown in the diagram overleaf: -

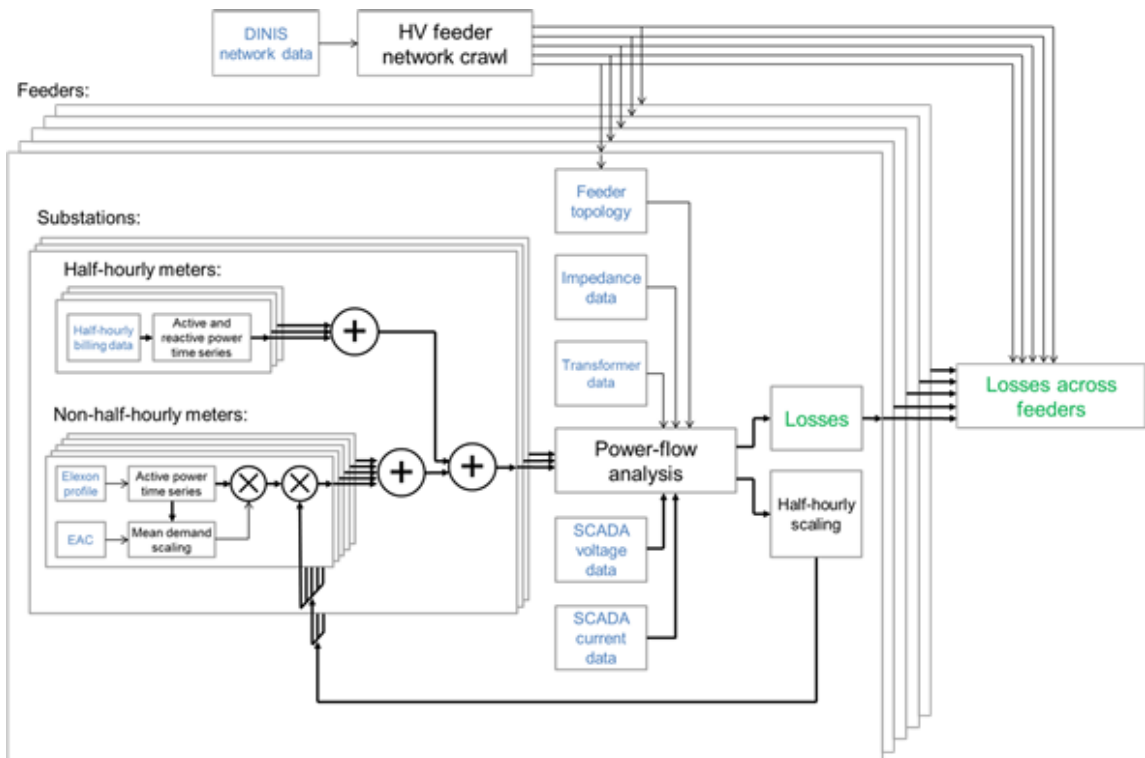

The results of the loss estimation method for the monitored HV feeders established at the start of the project have been found to be in good agreement to the loss assessments of these feeders using the measured data.

- Results** - one of the fundamental outputs from the HV feeder loss estimation result set is a scatter plot of mean total loss power versus feeder mean power, see below. Many other forms of analysis are provided, and these are detailed in the recent progress report.

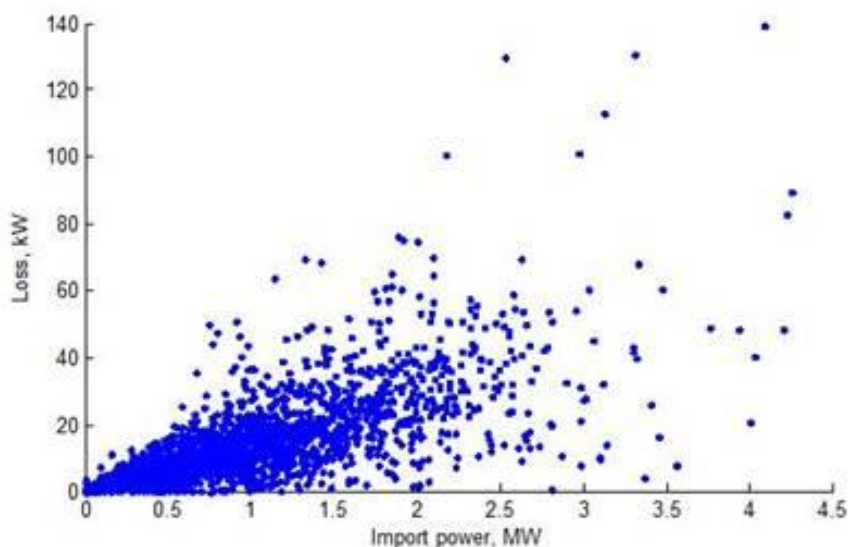

- **Validation** - In addition to overall method validation, a number of outlying results have been reviewed. The review of each feeder included: feeder topology, together with broad characterising metrics and drivers of the level of loss. The review also considered potential opportunities to reduce the losses, as a test of the capability of the analysis to support mitigation investigation work. The feeders included in the validation work are highlighted on the plot shown below, with the vertical axis now representing the annual cost of individual feeder losses.

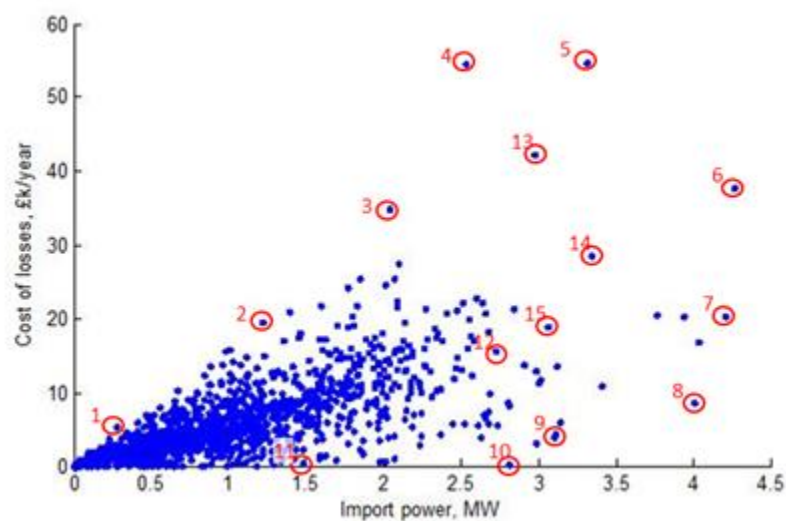

In all 15 cases reviewed, the estimated level of loss could be linked to characteristics of the network (e.g. length, cross-sectional areas number of connected transformers), and the load (e.g. how the load is distributed across connected substations, and the location of dominate loads on the HV feeder).

- **Signposting** – the HV feeder loss estimation process has demonstrated how HV feeders with high losses can be identified. These high loss feeders can then be reviewed to assess the cost-benefits of loss mitigation. The results also identify a set of higher loss individual feeder branches, and possible higher loss distribution transformers.
- **Learning** – Detailed points of specific learning are described in the latest six month project progress report.

4.4 FALCON

With respect to Losses, FALCON concluded: -

- **Dynamic Asset Rating (DAR)** - DAR was investigated within the WPD FALCON project and as this technique may allow higher levels of current to pass through an asset under certain conditions. By definition, losses in a dynamically uprated asset would rise in comparison to losses that would relate to an asset of larger capacity had traditional reinforcement taken place. In the context of a losses strategy, the

application of the technique would need an asset/network specific cost benefit analysis that considered the capacity benefit and cost of implementation, including any projected increase in losses during active periods.

- Automatic Load transfer (ALT) - ALT was investigated within the WPD FALCON project and indicates that the one-off static re-location of NOPs may have some potential to reduce losses. From the FALCON trials undertaken, relocating 11kV NOPs to the optimum position for losses can reduce the 11kV element of losses by 8% to 12% (the greater potential saving occurring on overhead networks). The potential benefits from NOP movements have also been looked at under WPD's Losses Investigation project.
- LV connected Energy Storage on an 11kV feeder (ES) - ES was investigated within the WPD FALCON project. The installed systems demonstrated effective peak-shaving at both individual substation and feeder level. This illustrated how energy storage shifts load in time, reducing load at a capacity constrained key point in time, only to increase the load at a less critical point in time. This reduction in peak current clearly reduces losses on the network, though the reduction in losses varies depending on the time of day that the demand is shifted to. However, the storage system has intrinsic technical losses (e.g. efficiency of the storage system, auxiliary loads associated with temperature management of the batteries etc.), that must be considered. Results from FALCON trials suggest the installed energy storage caused a net increase in losses, and that storage system losses would have to reduce significantly before this finding changed. Therefore the case for introducing any energy storage systems as an integral part of the Distribution network should include an assessment of the impact on losses.

4.5 EQUILIBRIUM

The focus of the Network Equilibrium project is to balance voltages and power flows across the distribution system, using three methods to integrate distributed generation within electricity networks more efficiently. The project considers three methods to improve voltage and power flows: Enhanced Voltage Assessment (EVA); System Voltage Optimisation (SVO) and a Flexible Power Link (FPL).

In some places, parts of the higher voltage networks are run in parallel with the lower voltage networks. This means there is more than one open point between the two levels of the network. The advantage of this configuration is that it allows loads to be better balanced, in most cases.

With the FlexDGrid and Equilibrium projects WPD has developed methods to monitor and automatically reconfigure networks. There are areas of the network where it is not possible to operate with parallel feeding arrangements (meshing) due to technical limitations. These can be due to loads, generation or fault levels.

The EVA method enables the two technology solutions, SVO and FPL, to be suitably modelled and understood. The EVA also demonstrated the value of expanding the current voltage statutory limits for 11kV and 33kV networks to +/-6% and +/-8% respectively. This

would facilitate an increase in utilisation of the existing system removing or deferring the need for additional asset investment. These models will also enable the network to be optimised in terms of full system losses, aligned with the learning from LV Network Templates and reducing the voltage as strategic points on the network.

The SVO method assesses the operational state of the network in real-time, considering connectivity and connected load and generation, to determine the optimal voltage and then communicate these calculated values to the on-site voltage control relays to implement the voltage change. The SVO system will then calculate the optimised voltage level, lowest value for generation inclusion and highest value for load facilitation, enabling on-site changes to voltage to occur. The system went live in March 2018 and has demonstrated significant network value through actively being able to control the voltage on the system.

The FPL device is an AC-DC DC-AC converter provided by ABB, which has been built, tested and was installed on the live Exebridge substation 33kV system in June 2018. This has enabled WPD to connect the Barnstaple and Taunton BSPs networks in parallel, providing the flexibility to move real and reactive power around the network to optimise the operation of the system and enable increased utilisation of the existing assets.

The FPL aims to enable active power transfer between two network groups whilst independently controlling reactive power between each of the two grid groups to provide additional voltage support. The device works by connecting the two, previously distinct, networks together with two back-to-back AC-DC converters, removing any phase displacement or fault level constraining issues that currently exist. The device itself produces relatively high levels of loss so it will only be used for short periods when the losses benefits outweigh the costs. This has been trialled and the benefits of the FPL have been demonstrated to ensure that there are no network violations on the system whilst enabling more generation to connect to the system.

4.6 Industrial & Commercial Storage Project

Four sites were selected to integrate different configurations in the application of storage. The fundamental operation of the energy storage system will be to store energy at times of low load seen on the network and dissipate energy at times of high load in order to actively manage the load on both the LV and HV networks. More specific applications include peak shaving; load shifting, transmission and distribution support, and islanding or emergency back-up. Through this project WPD will be able to develop an alternative connection agreement for behind the meter storage designed for Industrial & Commercial Customers.

At Spilsby WPD has installed a 50kW/210kWh with 30.75 kW of local PV generation to test peak shaving and PV self-consumption. We will show how storage charges from PV and at peak demand, storage can be used to eliminate peaks and reduce losses. Batteries designed to capture surplus electricity generated by a solar PV system can allow consumers to store solar electricity for use later in the day.

Site Name	Status	Application
Spilsby	Commissioned - Online	PV self -consumption
Boston	Commissioned - Online	Active Control by WPD - Nortec
Cardiff	Commissioned - Online	Part 1: Providing Grid Services Autonomously (Primary Frequency Support)
		Part 2: 3rd Party Controller Integration (In collaboration with KiwiPower)
Taunton	Commissioned -	Emergency Load Backup

At Boston WPD has installed a 50kW/210kWh with 21 kW of local PV generation. Third party controller integration allows the Powerpack user to change the battery behaviour during the operations. The controller will run multiple services on the customer's behalf. This could be for example a combination of frequency support services and wholesale trading activities.

At Cardiff WPD has installed a 50kW/210kWh with 8 kW of local PV generation. This project has two parts at this site. Part 1 will show the Energy Storage Capability to support the grid via Frequency Support Mode. Part 2 of the project adds 3rd Party Controller (KiwiPower) integration to test the communication interfaces, data monitoring and send remote direct commands to the batteries.

At Taunton WPD has installed a 50kW/210kWh with 50 kW of local PV generation this will demonstrate Backup & Islanding modes. Despite expectations, some storage systems will not provide power during a power-cut. Some battery storage systems however do have an 'off-grid' functionality, providing a limited amount of power to your premises, or to essential equipment (such as your fridge-freezer, lighting etc.). But a battery may run out of power before the power cut ends – or have already run out of power if it's been discharging all evening and the power outage starts late at night or early in the morning. If a system is required to operate in 'island' mode, i.e. continuing to provide power to critical loads during times when the distribution network is not available, it is important to understand the load handling and load shedding capabilities of the energy storage system.

As well as being capable of operating in 'island' mode, the battery/hybrid inverter must be rated to supply the power required by the load (including any inrush current). Typically, critical loads will be separated from other loads and connected to the energy storage system via a dedicated distribution board. An automated make and break contactor disconnects mains supply and connects the energy storage system to these loads, so that they receive a continuous electricity supply while ensuring power from the electrical

storage system is not fed back to the distribution network. Additional consideration should be given to the operation of protective devices and the provision of continuous earthing when operating in island mode. RCDs for the critical loads will need to be capable of operating under both supply conditions and not trip as a result of the transition.

5 Background and Theory

5.1 Reasons for Reducing Losses

The importance of reducing electrical losses on distribution networks is growing as a result of the increase in intermittent distributed generation and higher production costs. It has only been in the RIIO-ED1 period that DNO's have started to publically document a Losses Strategy. The energy lost in distribution creates a financial cost which is paid for by the customer. DNO's are obliged, as part of their licence, to reduce losses on their networks as far as reasonably practicable. The energy lost, which includes theft, accounts for unnecessary carbon emissions, which impacts climate change. Reducing losses effectively increases the network capacity. This is crucial with energy consumption likely to increase sharply in the near future, as a result of The Road to Zero Strategy and the uptake of new technologies such as electric vehicles and heat pumps. By reducing losses wherever possible, it could reduce the need for costly network reinforcement projects.

5.2 What are Losses?

Distribution network losses can be broadly defined as the difference between the electrical energy entering the distribution network, from base generation or embedded generators either upstream / same level / downstream networks, and the electrical energy exiting the distribution network, for consumption purposes and properly accounted for it, in percentage terms for a particular period.

Distribution network losses are conventionally broken down into two categories: -

- Technical losses;
- Non-technical losses.

Electrical losses are very difficult to measure accurately. As the meter-data from customers cannot currently be recorded accurately or frequently therefore as a consequence non-technical losses are difficult to account for.

The SOHN Losses Report [1] suggests that losses use up approximately 7% of the power supplied to the distribution network.

The source of the losses can be even more difficult to ascertain, as there are a limited number of monitoring points on the lower voltage networks and the measuring tolerances on some meters are larger than the magnitude of the losses. The following sections (5.3 and 5.4) describe the various ways losses can occur.

5.3 Technical Losses

The total amount of technical loss is made up of a fixed component (a function of the network itself, independent of the load on the network) and a variable component which is dependent on the level of load on the network. Variable losses may also be impacted by the power factor, network imbalance and the effects of harmonics.

5.3.1 Fixed Losses

Some electrical energy is dissipated by network components and equipment such as transformers or conductors as a result of being connected to the network and being energised. Even if no power is delivered to customers, the system has losses just because it is electrically energised. These losses take the form of heat and noise and are called 'fixed losses' or 'no-load losses', because they are independent of how much electrical energy the network delivers. Transformers' energisation is responsible for the majority of the fixed losses (although this equipment also gives rise to variable losses). These losses occur in the transformers' core and are called 'core losses' or 'iron losses'.

Two types of core losses are known to exist: -

- Hysteresis losses are losses that stem from the reversal in magnetic polarity of the steel in transformer cores in every ac cycle. This causes the material to pulse (which emits a humming noise) and to heat up.
- Eddy current losses are losses that stem from the circulation of induced currents in conducting parts that are not copper windings, such as the iron body or steel core of the transformer.

Besides transformer inefficiency, another source of fixed losses is the electrical insulation in network equipment. Imperfections in electrical insulation leads to the flow of very small currents across the insulation in transformers, overhead lines, underground cables, and other network equipment. These types of fixed losses are called 'dielectric losses' or 'leakage current losses'. Dielectric losses of underground cables are independent of the cable load, but are related to the cable operating voltage, so dielectric losses are regarded as a no-load loss. The dielectric losses per unit length per phase of underground cable are given as follows: -

$$\Delta A_o = 3U_o^2 \cdot \omega \cdot C_o \cdot \tan\delta T * 10^{-9}$$

$$C_o = \frac{\epsilon_r \cdot 10^6}{18 \ln \frac{r_2}{r_1}}$$

Where: -

ΔA_o = dielectric loss

U_o = rated phase to earth voltage

ω = angular frequency

C_o = Capacitance per unit length of cable

ϵ_r = relative dielectric constant

r_1 = diameter of conductor
 r_{21} = diameter of insulation
 $\tan\delta$ = dielectric loss angle.

Corona losses, for overhead lines occur when the operating electric field intensity on the conductor surface of a high voltage line exceeds the air breakdown strength, corona discharge will result. Corona discharge increases the active power and electricity energy losses of the lines, so the calculation result of corona losses of high voltage overhead lines serves as one of the important bases to verify whether the conductor selection is economical and reasonable. In general corona losses should be smaller than 10% of resistance heat losses. They vary with the voltage level, the physical wire diameter, and with weather conditions such as rain and fog. Corona losses can generate audible and radio-frequency noise and is often seen as a glow in the air adjacent to conductors.

While fixed losses do not change with current, they depend on the applied voltage. However, as the applied voltage is relatively stable while the network equipment is energised, they are essentially fixed. Therefore, fixed losses are a function of the network itself and depend mainly on the number of energised components. In this respect, measures to reduce fixed losses mainly aim to reduce the number of energised components or to increase their efficiency. In general, fixed losses contribute too roughly between a quarter and a third of the total technical losses on distribution networks.

5.3.2 Variable Losses

The variable component of losses is created by the heating effect of electricity passing through the cables and windings. All conductors, whether they are coils in transformers, aluminium or copper wires in overhead lines or underground cables and even in switchgear, fuses, or metering equipment, have an internal electrical resistance which causes them to heat up when carrying electric current. As a result, the variable losses change as power flows increase and decrease (proportionally to the square of the current), transmission networks experience a lower level of losses because at higher voltages a lower current is required to transmit the same amount of electric power. Conversely, distribution networks at lower voltages are subject to a higher level of losses. Additional factors such as the effect of network imbalance, power factor and power quality can also have an impact on variable losses, as they influence the value of the currents flowing through the conductors.

Additionally, variable losses are also dependent on the length and the cross section of the conductor as they vary in proportion to the conductor resistance. The resistance of a conductor decreases as its cross sectional area increases. Therefore, the effect of losses is reduced with larger cable sizes. A similar principle also applies to the variable losses in transformers, where the cross sectional area of windings, and the materials used in them, influence the variable losses. The maximum efficiency of a transformer occurs when the variable copper losses become equal to the fixed iron losses. Inadequate connections between network equipment and deteriorated conductors can also be a source of this type of losses, as they can cause hot spots due to an increase in the equivalent resistance.

In general, variable losses contribute roughly between two-thirds and three-quarters of the total power system technical losses. In essence, measures to reduce variable losses can be

classified under two main influencing factors of power flows and resistance and how they apply in the wider network. They either aim to lower the system power flows or to lower the resistance of the transportation paths. A reduction in the utilisation levels of network assets can contribute to lower both current and resistance. Any higher capital investments required for loss reduction must show a positive lifetime cost benefit analysis.

5.3.3 Phase Imbalance

A network which does not have its load evenly distributed across all three phases will have higher currents in at least one phase meaning it is not optimised for losses. There will also be currents flowing in the neutral conductors if they are present. Due to the quadratic dependence of losses on current discussed overleaf, this load imbalance across the three phases will increase losses.

Imbalance is found on all parts of the low-voltage (LV) network due to customers who use one or two phases having different load consumptions. On the high-voltage (HV) network, imbalance is due to the uneven distribution of single-phase transformers or two wire spurs and different loads on each phase for three-phase customers. The most obvious way to reduce phase imbalance is to carefully balance the aggregated load on each phase, but as customer consumption is not always predictable and varies at different times of day, this can be difficult.

A rural LV overhead network could be rebalanced across phases relatively simply by moving the overhead service connection to a different phase of the overhead main. This is more difficult on an urban underground LV network, as this requires existing service joints to be excavated and new joints made to move customer supplies to different phases.

Interventions to alter connections will help balance customers and load across a network based on the maximum demands of those customers. Balancing load profiles over time is very complex, so some imbalance will always occur at certain times of the day. Loads will change in the future so any action taken to balance the network will have to consider what changes are likely to occur in the future.

Analysis of the data collected by the LV Templates, see section 6.2 for more information on LV Templates project, monitoring equipment has highlighted areas of the network where imbalance at the distribution transformer is a significant issue which is increasing losses.

Using substations that are part of LV Templates project, WPD has identified that the phase imbalance in the LV network can lead to neutral currents at around 35% of the phase current. More recent work from the Losses Investigation Project suggests that ratios of neutral current to phase current are higher still. Figure 1 below shows neutral current versus mean phase current for 390 3-phase LV feeders during 2017 that are being monitored as part of WPD's Losses Investigation Project. From this it can be seen that for the majority of feeders have neutral current/mean phase current ratio above 0.35. Neutral current ratios tend to be higher for feeders with lower mean current.

Please see overleaf for the graph.

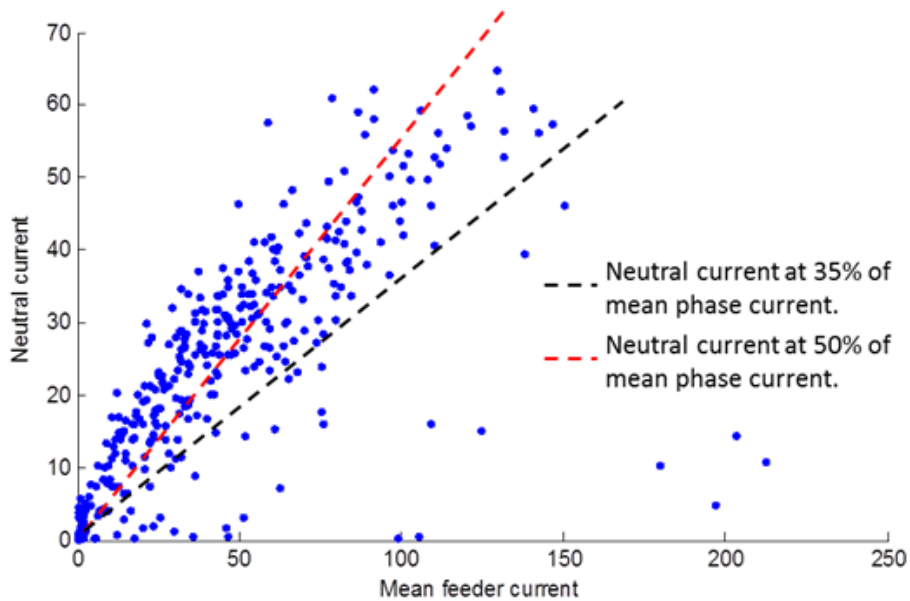

Fig. 1 – Mean neutral current vs mean phase current

5.3.4 Power Factor

There are two ways to define the power in a system. The *real power* is the capacity of the system to do work. The *reactive power* is the product of the voltage and the current flowing. The *power factor* is the ratio of the real power to the reactive power. Where the power factor is less than unity the current has to increase to deliver the required amount of real power, which results in a loss. This has historically been an issue for installations used by industrial and commercial customers, where most motor loads or power electronic loads were seen. Developments in domestic power electronics and heat pumps will mean that this will start to be seen occurring in more domestic networks.

Since 2010 WPD has been including an excessive reactive power charge for HV and LV half hourly metered, via the *Use of System Charge*, have a power factor of 0.95 lagging, this is to ensure that the reactive power is kept to the minimum as with any load the WPD has to cater for the reactive power for the sizing of the circuit even though that reactive power is not being used effectively.

5.3.5 Harmonics

Harmonic effects are essentially distortions to an ac current profile. They can occur in transformer windings because the ac magnetising current is not perfectly sinusoidal. However, this usually occurs on the triple harmonics (3rd, 6th, 9th etc.) so on a normal three-phase system they are all in phase and do not result in any real harmonic voltages. However, if other equipment connected to the network produces harmonics they will not cancel in the neutral conductor. These can then cause additional I^2R losses, as in real terms the losses formula becomes I^2R+VH where H=harmonics on the network, this increases the overall load on the network which in turn increases the losses.

LCT's can produce harmonic distortion. For example, Electric Vehicles (EV's) require a DC supply for charging. This requires a rectifier, which produces a short, sharp pulse, distorting

the sinusoidal waveform of the AC supply. WPD has completed a project entitled Electric Vehicles Emission Testing, the conclusion of which is that EV charging does not significantly increase harmonic distortion. WPD will continue to review this element of losses as other LCT technologies emerge.

There are a number of papers appearing that appear to indicate that where there are large numbers of wind turbines, large solar parks or internet hotels that certain terminations on the 33kV networks are failing prematurely, to this end the ENA LCT group has asked the ENA Power Quality group to review if the gap in the standards that existed was the problem that allowed high frequency harmonics to enter the 33kV network and cause termination failures. Originally ENA ER G5/4-1 covered the network up to the 50th harmonic (2500Hz), whereas EN 61000-2-2 covered up to the 40th harmonic (2000Hz), but with the recently re-written EN 61000-2-2 EMC standards now cover up to (30000Hz), the issue could be that previously the failures were brought about by there being no overlap between the standards.

5.3.6 11kV Network Optimisation

Most electricity networks are designed to provide the best level of customer service with regard to supply quality and faults. In many cases this means that a network is not optimised with respect to losses. Automatic Load Transfer was investigated within the FALCON project and the results indicate that the re-location of system split points or Normal Open Points (NOP's) may have some potential to reduce losses.

The potential to reduce losses from moving NOP's has been considered as a small part of WPD's FALCON project, and has also been considered (briefly to date) under WPD's Losses Investigation Project. Evidence from both these investigations suggests that there is potential in reviewing the current NOP positions on HV networks.

Estimated annual cost savings from NOP-change loss reductions, for three feeders being considered by the losses investigation project, are £405, £2,892 and £599 p.a. This suggests:-

- Modest per feeder savings are possible, though care would have to be exercised in the amount of investment/expenditure that would be economically viable to achieve the benefits (e.g. feeder identification/assessment/modelling and implementing any mitigating network automation/fault passage indication required);
- Over large numbers of feeders the cumulative savings might be material; but
- Significant variation in benefit may occur. There is not a sample number that can reasonably be projected from.

It should be noted that: -

- This is not a saving to WPD, but a saving to end consumers through WPD further optimising its network operation;
- Altering NOP's will change the available capacity on the feeders involved, and will change the numbers of customer connected to a feeder; however,
- Customer numbers may be mitigated through post-fault automated switching schemes based on fault passage indicators.

Both investigations suggest that the improvement arises through a change from the existing NOP to a preferred static NOP, i.e. there is little further benefit arising from having a dynamic NOP position that changes over peak/off-peak, weekday/weekend or summer/winter periods.

To identify preferred NOP positions and assess potential benefit, some form of modelling is necessary. This requires network data and a (per distribution substation) load model to allow power flow analysis to be iteratively performed. The FALCON project and the Losses Investigation project have tried different approaches to identifying the preferred open points and further consideration of the most cost-effective method is required. The Losses Investigation project is actively investigating how to model losses on a large number of HV feeders, which is a significant portion of the work required to then go on and identify the potential for changes to NOP positions that could reduce losses. The extent of the Losses Investigation project work is that it has identified the repositioning of NOP as one way those HV feeder losses might be reduced, but it wasn't within the scope of the project to produce a full list of possible re-location candidate NOPs. Loughborough University could undoubtedly help with doing this as a follow-on piece of Losses Strategy work. WPD will consider how to use the process knowledge gained through the Losses Investigation project to further investigate NOP optimisation once the Losses Investigation project has reported (Q1 of 2019).

5.3.7 Network Meshing

In some places, parts of the higher voltage networks are run in parallel with the lower voltage networks. This means there is more than one open point between the two levels of the network. The advantage of this configuration is that it allows loads to be better balanced, in most cases.

The FlexDGrid project previously and now in the Equilibrium project WPD is developing methods to monitor and automatically reconfigure networks. There are areas of the network where it is not possible to operate with parallel feeding arrangements (meshing) due to technical limitations. These can be due to loads, generation or fault levels.

The FlexDGrid project, which investigates the management of fault levels, showed that the installation of a Fault Current Limiter (FCL) has significant losses benefits through enabling the parallel operation of two or more transformers. Using an average network approach and the standard Birmingham 132/11kV transformer, the FlexDGrid work showed that the windings of unmeshed transformers can have an uneven load distribution, typically a 70% to 30% split. Through the installation of an FCL and subsequent network meshing, it allows these uneven windings to be balanced so that each takes 50% of the load. WPD estimates that this could provide savings of around 94 MWh per annum per substation.

Enabling networks to be meshed will smooth load profiles and reduce the overall losses. As a part of the Equilibrium project, the flexible power link will demonstrate how innovative power electronic devices can be installed to efficiently transfer real and reactive power flows between previously unconnected networks. The flexible power link will balance power flows, reducing energy miles and thus network losses.

5.3.8 Demand side response

Due to the non-linear nature of variable losses, assets working at their maximum capacity will lead to significantly more losses than those with a reduced loading. The scale of variable losses can therefore be reduced if measures can be taken to reduce the demand on the network or by reconfiguring networks to transfer loads from highly loaded circuits to lower loaded circuits.

Following successful innovation trials, WPD is actively using DSR solutions to help manage peak network loading as part of our network management portfolio. The FALCON project demonstrated the ability to contract with commercial and industrial DSR to manage peak demand periods in the Milton Keynes area. The Entire project followed up this work with a focus on commercial revenue stacking to make such services more economically viable. The SYNC project highlighted that DSR can also be used to turn-up demand, which can help with generation dominated networks. WPD has taken the learnings from these projects and used them to inform its Flexible Power offering, which is the customer facing brand to commercially contract with flexibility providers. During 2018 WPD has awarded DSR contracts totalling 28MW.

5.3.9 Virtual Private Wire

WPD's Virtual Private Wire (VPW) investigation investigated options to increase local balancing. Initial work focussed on replicating the incentives for self-consumption offered by private wires through a virtual private wire. This could theoretically help reduce flows on the wider network and reduce losses. However such incentives are based on the avoidance of system costs and would not get the regulatory support required to deploy them. Further work was carried out on the options for providing more cost reflective pricing through DUoS signals.

5.4 Non-technical Losses

Non-technical losses are caused by actions that are external to the power system. They refer to lost energy that is not directly related to the transportation of electricity and occur independently of the physical, technical characteristics of the network (technical losses). Cases of non-technical loss cannot be fixed by upgrading equipment or altering network design. Instead investigations, audits and collaborations with other bodies are required. This kind of loss involves the abstraction of electricity with a loss of revenue to both the network operator and the supplier.

5.4.1 Unmetered Supplies

Not all supplies in distribution networks are metered. There are many items of electrical equipment where it is neither practical, nor cost-effective, to measure energy consumption using conventional meters. In these circumstances, there are legitimate unmetered supplies whose energy demand is estimated rather than accurately metered. All unmetered connections can be treated as any other type of load, provided that it is registered, properly estimated and accounted for. Moreover, customer-related unmetered connections (e.g.

public lightning) or some of the DNO's own consumption (e.g. auxiliary services of substations) can be adequately contracted from an energy supplier and paid for by regular tariffs as any other normal consumption. Therefore, unmetered consumption, whether related to customers or the DNO, can be excluded from non-technical or technical losses, respectively, provided they are adequately contracted. Only the difference between the real and estimated unmetered consumptions is part of non-technical losses.

In the case of equipment such as street lighting, traffic lights and road signs it is not practical to meter every unit. Instead bills are estimated using the power rating of the equipment, the approximated time of use and the number of units. It is not uncommon for these estimates to be inaccurate or an inventory of equipment to be out of date. In order to reduce these losses, DNO's must work alongside customers with unmetered supplies to improve the accuracy of inventories, to produce more accurate bills.

5.4.2 Theft in Conveyance

There are several ways in which electricity can be taken from the network illegally. Theft and fraud generally account for a majority of the non-technical losses from the network. These are important challenges for the DNO, and require a concerted effort from a range of stakeholders to mitigate them. In addition to theft and fraud, there are serious safety aspects to be considered. It is difficult to gauge the exact extent of this type of losses as a large proportion of it is likely to go undetected.

Situations where illegal connections to the network are made, which do not have a registered supplier or a meter installed, are referred to as theft in conveyance. Detecting such illegal connections is very difficult. Often detection comes as a result of investigations by authorities for other reasons. In many cases, theft in conveyance is connected to other illegal activities, which prompts investigation and detection. Routine visits to premises for fault repair, equipment replacement tasks and meter operator visits to replace meters also often expose cases of theft.

5.5 Distributed Generation and DSO

Traditional power stations are large and centralised; therefore it is justifiable to connect them directly to the National Grid transmission system. In contrast to this, renewable energy sources and storage tend to be smaller and more distributed around the country; meaning they are usually connected to local distribution networks. This disrupts the traditional flow of power from generators to transmission networks, to distribution networks, to the customer. If the energy from distributed generation is used locally (and within a suitably short period of time) then this reduces losses.

As WPD moves towards a DSO way of working there will be a need to manage energy flows across the network to increase utilisation and balance demand and generation. This has the potential to increase losses if power flows increase or demand and generation cannot be balanced. Alternatively it could reduce losses if the network was perfectly balanced. This balance must be achieved against an economic and efficient measure so the cost of losses should be considered. Work completed for the ENA Technical Losses Working Group by the Engineering Consultants WSP has shown that losses could increase as a result of DSO

flexibility, smart solutions allow greater utilisation of network assets and losses increase as a consequence.

5.6 Which Parts of the Network Produce the Most Losses

Network modelling work described in the SOHN losses report [1] predicted that the distribution of electricity at LV produces the most losses on the WPD network. The service cable and LV cables supplying electricity to properties account for 25% of the total losses. The distribution transformers add another 22% with the 11kV network accounting for another 25%. The higher voltages (33kV and 132kV) make up the remaining 28%. These percentages vary between urban and rural networks. See graph below.

Figure 2 shows the breakdown of GB distribution losses calculated using representative network models. Annual losses are estimated to be between 5.8% and 6.6% of energy delivered. It can be seen that about three quarters of losses occur in LV and HV networks.

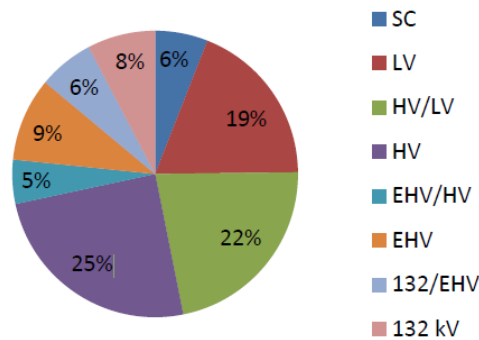

Figure 2: Breakdown of GB losses- SC – service cable, LV – low voltage, HV – high voltage, EHV – extra high voltage

6 Improving Understanding

In order for WPD to reduce losses effectively, there is a need to have a far better understanding of them. WPD needs to quantify the losses that are present on the network; identify where they occur; understand why they occur and have methods for predicting what effect certain actions taken to reduce losses will have on the losses.

6.1 Quantifying and Monitoring

Raw levels of losses in kWh are of significance for any DNO, but a direct comparison with other DNO losses levels is more difficult: indeed, DNO losses depend not only on the network structure, but also on network energy flows.

Losses rates make a comparison between loss and energy flow levels. Consequently, they provide reference values that may be comparable between networks, even if they are detailed by voltage level for relevant benchmarks.

Raw losses values and losses rates have to be calculated over long periods (at least 3 years) to ensure stability and robustness, as total losses for a given year may not be significant due to variability and uncertainty (due to data collection hazards or climatic conditions). In order to see the effect of reducing losses WPD needs to be able to determine the baseline level of current losses. The Losses Investigation project aims to establish such a baseline for several highly monitored LV and HV feeders picked to be representative of the main UK network topologies. This will allow WPD to better understand the locations of the losses on the network as well as the main causes. The project will also establish the level of information required to accurately assess the losses across the rest of the network and enable a more targeted approach to reducing losses. There is more detail on this project in Section 4.3.

To measure overall losses on the network, the power entering the network from the transmission network and the power which leaves the network are compared. The measurement at the customer end can be very inaccurate in the case of domestic customers as some meter readings can be estimated values. Statutory limits for domestic energy metering is $[\pm]1.5\%$ accuracy. This rough calculation does not discriminate between technical and non-technical losses, nor does it give any indication of where the losses occur. There are other monitored points along the network, typically substations, which can help identify where the losses occur.

WPD's standard LV distribution cabinets have always been manufactured with a simple current transformer (CT) fitted, which measures the peak load. When transformers are replaced, they are now installed with more accurate current transformers, which are wired to a terminal block where more advanced monitoring equipment can be attached. On the EHV network half-hourly loading data is recorded at all the substations. However, currently there are areas of the network, especially at LV where there is no monitoring at all.

6.2 Smart-meters

The roll out of SMETS 2 smart meters has the ability to change the nature of network monitoring. It still needs to be considered that the statutory limits for domestic energy metering is $\pm 1.5\%$ accuracy. DNO's should have the access to data points representing the consumption across their respective networks and LV feeders. This smart meter data will be readily available in providing data for the relevant circuits and updated on far shorter timescales, thereby providing vastly improved data on network loadings. Smart meters are also being installed at other points on the WPD network, so there will be a more complete picture of load flow across the network. Provided the SMETS 2 smart meter roll out is completed by the deadline of 2020, it is important to ensure that the necessary data analysis tools are in place to make maximum use of the data generated.

The deployment of smart meters should enable DNO's to implement a number of key strategies to manage losses. Firstly, customers could be incentivised to use less energy at peak times by using time-of-use tariffs, which would flatten the network load profile to reduce losses. Secondly, it would enable areas of high loss to be identified, so that targeted action can be taken to reduce them. Finally, it would allow for real-time network management, meaning generation from both distributed and non-distributed sources and power flow across the network could be controlled to match present demand.

6.3 Computational Modelling

In order to forecast, what will happen on the WPD network in the future and to determine what is happening on the unmonitored parts of the network, the most powerful tool is computational modelling. Modelling effectively creates a virtual, fully monitored network which can then examine and test new ideas. Using the modelling tools WPD should be able to map where losses occur on the network, allowing for a targeted approach to loss reduction. Modelling can also be used to predict the effect of future changes to the network, so that the effect on losses of all possible future actions can be considered before the changes are actually carried out.

WPD's LV system modelling tool includes losses calculations for each scenario used. The WPD 11kV system modelling tool also includes losses calculations. At LV and 11kV, planners are able to comply with the majority of losses designs by using the updated selection of cables and transformers made available in 2016. At EHV WPD currently uses two system modelling tools, PSS/E and IPSA. PSS/E can create losses calculations, it is envisaged that PSS/E will become the standard system within WPD by Q4 of 2019. This date has been delayed due to a compatibility issue between the latest release of PSS/E and the WPD corporate IT hardware/operating system, which will be refreshed during 2019. Whilst all EHV designs are bespoke, WPD has completed work to provide templated solutions for generation connections, these templates incorporated the losses impacts.

Modelling should become even more useful once used in conjunction with smart meter data. By feeding the data into the model, this will be able to produce models of the network in real-time. Data at specific metering points can then be predicted and compared to the real data, to establish the success of the model. The software will need to be redesigned to incorporate this feature. Once this level of insight into the network is established, it will be

possible to create more targeted losses strategies, leading to far more effective loss reduction activities.

6.4 Harmonics

Harmonics are generated whenever non-linear loads are connected to the network. The currents generated by harmonics cause problems on the network and contribute to increased levels of losses, because of the harmonics $I^2R + vH$ add to the total losses in the distribution transformers. Eddy currents in transformers will increase with the square of the harmonic frequency, so can become significant. Within the UK a derating factor, K factor, can be applied to transformers to take account of the harmonic currents. K factor is a weighting of the harmonic load currents according to their effects on transformer heating.

WPD network monitoring does not routinely measure harmonics. Assumptions based on calculations of known harmonics can be inaccurate due to the effects of diversity, which apply to harmonics in a similar way to network loadings. The only accurate method of assessing harmonic spectra is to measure the harmonics using monitors on the network. WPD is continuing to record data from the LV Templates monitored network, which gives WPD an indication of harmonic effects by measuring Total Harmonic Distortion (TDH) across an individual distribution substation area.

The standard retro-fit LV harmonics monitoring solution is capable of recording Total Harmonic Distortion (THD) data where appropriate. Reducing harmonic effects is difficult; the principal approach is to ensure that customers use devices that produce minimal harmonic effects. The harmonics can also be reduced by fitting harmonic filtering devices, but the economic benefit of reducing harmonics is not great enough to justify the cost of the filters.

6.5 Asset Replacement

Asset replacement is the ongoing and most direct way in which WPD can reduce technical losses. From a losses point of view old transformers and underground cables encompass the majority of assets which provide the best value to a DNO and customer to reduce the losses seen on a network. With this in mind it then becomes part of the business as usual that WPD will be changing pre 1958 transformers for newer models which will reduce overall losses as new transformers have lower losses than old ones. In addition the variable losses in cables can be reduced by using cables with larger cross sectional areas, which also increases their capacity. Where overhead line conductors are replaced WPD aims, where possible, to replace smaller diameter conductors with larger diameter conductors.

7 Policies and Actions

7.1 Assessment

This section contains all the various areas that WPD are currently focusing on with a view to reduce losses going forward. These actions can be split into three areas: - actions completed before 2018, actions completed during 2018 and plans for 2019 and beyond. These actions will allow WPD to reorganise the network to make it run more efficiently with the revenue protection, identifying actions that can be taken to prevent or reduce energy loss to theft or unmetered supplies. However, there are also some discussions, particularly in the network design section, of policies where WPD will be able to implement in the near future, with reference to the innovation projects which are investigating them. Where appropriate, WPD has referenced the SOHN recommendations to which the actions correspond to.

7.2 Actions Completed Before 2018

- The discontinuation of cable tapering on all feeder and service cables;
- A comprehensive programme of stakeholder engagement including biennial stakeholder consultation events;
- Reducing cable lengths;
- Rationalisation of transformer sizes and application;
- Start of voltage reduction across WPD;
- The on-going reduction the variable losses in underground cables by removing the smaller cross-sectional area cables from normal use;
- The development of a new losses page on the WPD website;
- Creation of a Losses Engineer post within the Policy Section;

7.2.1 Cable Tapering

Since 2012 WPD as part of the business as usual have installed link disconnecting boxes (LDB's) between LV substations on non-tapered LV mains cables, thereby providing the possibility of mesh connections and back feed potential under fault conditions.

In addition since the start of 2015 WPD has amended the design policy and now all designs of the LV mains underground cable network are designed without cable size tapering. Networks shall be planned using either 185mm² or 300mm² Wavecon cables. The size chosen for a particular scheme will be used throughout that scheme and tapering is no longer considered. (Recommendation 13)

7.2.2 Cable Sizes

To reduce the variable losses in underground cables either a lower resistance conductor must be used e.g. using a copper conductor or the cross-sectional area of the conductor needs to be increased. Once an underground cable is laid and the cable trench is reinstated, it becomes expensive to make alterations to the underground cable. The

opportunity to reduce losses exists when an underground cable is installed or replaced. The resistance of a 185mm² Al LV cable is around half that of its 95mm² equivalent. The additional cost of the cable is less than £10 per metre, a marginal cost when compared to the excavation costs, which can be between £50 and £100 per metre. Whilst this cost is marginal, it is only appropriate to oversize cables in some cases. (Recommendation 8)

In the case of underground cables on the LV network, it is cost-effective to uprate them, but only in conjunction with other works.

For LV service cables there is no justification in the targeted uprating of cables, but it can be demonstrated that a benefit exists in discontinuing the smallest service cable size of 16mm². The cost of this will be around £0.33m per year at current prices. (Recommendation 4)

On the LV mains UGC network, WPD will install the next size up for all our cable designs in the RIIO-ED1 period. This will cost us around £2.89m per year at current costs. This means WPD will discontinue the installation of 95mm² LV mains cables.

At 11kV it can be demonstrated that a benefit exists, in new build work, to discontinuing the smallest cable size of 95mm², costing around £1.42m per year at 2014 prices.

In 2013 WPD renewed the MV framework contract, with the 33kV cable supply WPD took the opportunity to harmonise our cable sizes with other voltages. WPD discontinued the 240mm² size and standardised on the following 185/300/400/630 and 800mm² cable sizes.

7.2.3 Transformers

Since 2015 all newly manufactured small, medium and large power transformers are required to meet EU Ecodesign Regulation 548/2014, which ensures that transformers meet certain standards of efficiency. Ecodesign has now become business-as-usual for WPD and the requirement to replace transformers with more efficient ones is well established. At 11kV the distribution transformers used on the WPD network comply with the 2015 Ecodesign directive. Since 2011 all the WPD transformers purchased at voltages above 11kV, the transformer specifications already exceed the requirements of the Ecodesign 2015 directive. (Recommendation 9)

The variable losses in a transformer are much lower when the unit is partially loaded and increase quadratically as a unit becomes fully loaded. It is therefore possible to reduce the overall losses by oversizing transformers when they are installed. By using customer meter data to estimate the loading on all of the 500kVA, 800kVA and 1MVA 11kV transformers in the South West, WPD has completed a CBA which identified which transformers on the network are worthwhile oversizing. WPD found that it would be justified to oversize 325 transformers, which would save 854MWh per annum in losses. (Recommendation 8)

Using data from the Centre for Sustainable Energy (CSE) WPD forecasts that the majority of up-take of LCTs will be on approximately 7% of our network; in these cases investment in oversized transformers is clearly justified. WPD as part of the business as usual aim to oversize on average 109 transformers per annum at a cost of around £0.11m per annum.

The smallest size of ground-mounted transformer is a 315kVA unit. There is benefit in oversizing these transformers universally on installation. WPD plans to install a minimum ground-mounted transformer size of 500kVA in RIIO-ED1. WPD would aim to oversize on average 448 transformers per annum at a costing approximately £0.38m per annum.

Older designs of ground-mounted transformers have much higher losses than new designs. Whilst it is not efficient to replace all transformers early simply to reduce losses, it is envisaged to replace very old units and large capacity units in advance of their normal asset replacement plan. WPD aims to replace 1,996 pre-1958 ground-mounted distribution transformers (the entire fleet of these units) in the RIIO-ED1 period at a cost of roughly £2m per annum. (Recommendation 10)

Pole-mounted transformers are relatively small in size, but there is a benefit in oversizing the smallest transformers universally on installation. WPD plans to install a minimum pole-mounted transformer size of 25kVA (single-phase) and 50kVA (three-phase) in RIIO-ED1. WPD aims to oversize, on average, 575 transformers per annum, which will cost around £0.30m per annum.

7.2.4 Reducing Cable Lengths

Working with SOHN Associates WPD has used recent designs for 30 domestic and commercial development schemes from across the licence area as templates for the losses calculations. WPD re-designed the schemes using shorter LV cable lengths to work out the relative impact of the reduced losses and the increased transformer population. The results showed that economic loss optimisation is predominantly driven by tapering, phase balance and choice of larger conductors. However, there is little opportunity at current demand levels for further improvement by shortening cable lengths and including additional transformers. (Recommendation 11 & 12)

During 2018 WPD plans to investigate and model the likely level of demand which will be seen as a result of LCT uptake. Once this is done WPD will review the work done assess optimum cable lengths.

7.2.5 Voltage Reduction

The LV Templates project provided data on the voltages seen on the LV network and concluded that there is scope to reduce the network voltage and remain within the statutory voltage parameters. Reducing the voltage will reduce the overall demand and will contribute to loss reduction.

The voltage on the LV network can be reduced in many ways but WPD has chosen to change the settings at the primary substation level. At this point on the network, the voltage change can be made automatically and while the network remains connected.

WPD has completed a programme of voltage reduction in the South Wales area, and results have shown that a 0.88% reduction in primary voltage resulted in an average demand drop of 1.16%. As a result of this, losses increased in percentage terms but this is because the

current has to be slightly higher to deliver the same power, which increases the variable loss, but the power required is lower, therefore overall losses are reduced. Based on these results, WPD has now commenced a programme of voltage reduction across all the WPD licence areas, the current status is, 1403 completed substations and 714 outstanding substations, with a target completion date of 2020. (Recommendation 6)

In some places, parts of the higher voltage networks are run in parallel with the lower voltage networks. This means there is more than one open point between the two levels of the network. The advantage of this configuration is that it allows loads to be better balanced, in most cases.

The FlexDGrid project previously and now in the Equilibrium project WPD is developing methods to monitor and automatically reconfigure networks. There are areas of the network where it is not possible to operate with parallel feeding arrangements (meshing) due to technical limitations. These can be due to loads, generation or fault levels.

The FlexDGrid project, which investigates the management of fault levels, showed that the installation of a Fault Current Limiter (FCL) has significant losses benefits through enabling the parallel operation of two or more transformers. Using an average network approach and the standard Birmingham 132/11kV transformer, the FlexDGrid work showed that the windings of unmeshed transformers can have an uneven load distribution, typically a 70% to 30% split. Through the installation of an FCL and subsequent network meshing, it allows these uneven windings to be balanced so that each takes 50% of the load. WPD estimates that this could provide savings of around 94 MWh per annum per substation.

7.3 Actions Completed During 2018 and ongoing actions

- The continued pro-active replacement of 1,996 distribution transformers;
- The design intervention for losses on new installation of 8,184 distribution transformers and 11,880 kilometres of underground cables;
- A review of the WPD policies to ensure losses are a priority consideration for all of our investment decisions;
- The update of the existing modelling tool for LV mains of the WPD network, to output direct losses data and be compatible with smart-meter data;
- A comprehensive programme of stakeholder engagement including biennial stakeholder consultation events;
- The on-going development of the losses page on the WPD website;

7.3.1 Asset Replacement

WPD's work to uprate assets continues through RIIO-ED1. The detail of the plans are shown in section 9.4

7.3.2 Network Design and Policy review

WPD's LV system modelling tool includes losses calculations for each scenario used. The WPD 11kV system modelling tool also includes losses calculations. At LV and 11kV, planners

are able to comply with the majority of losses designs by using the updated selection of cables and transformers made available in 2016. At EHV WPD currently uses two system modelling tools, PSS/E and IPSA. PSS/E can create a losses calculation, it is envisaged that PSS/E will become the standard system within WPD by Q4 of 2019. This date has been delayed due to a compatibility issue between the latest release of PSS/E and our corporate IT hardware/operating system, which will be refreshed during 2019. Whilst all EHV designs are bespoke, WPD has completed work to provide templated solutions for generation connections, these templates incorporated the losses impacts.

7.3.3 Stakeholder Engagement

The WPD stakeholder engagement plans continue and full details are detailed in Section 5. In 2017 WPD hosted the latest Stakeholder Engagement session. At that event WPD shifted the focus of the losses work and introduced plans to target electric vehicle and other Low Carbon Technologies demand as the next significant area of increased losses on WPD network. During Q3/Q4 of 2019 the next Losses stakeholder event will take place.

7.3.4 Losses pages on WPD website

WPD has developed and published a set of pages related to losses on the WPD website. They explain losses in more detail and lead into actions that are being taken to reduce losses as a result.

The WPD Losses page, along with all the DNO's losses pages can now be accessed via requisite links from the ENA Technical Losses page.

7.3.5 Revenue Protection - Supplier Side Abstraction

WPD investigative work for suppliers uncovers around 8,000 cases per year of illegal abstraction. Around 1,000 of these cases are related to cannabis production and, as a result, WPD works closely with local police. WPD identify around 2.8GWh per year of lost units which are passed through to suppliers for entry into the settlements process.

WPD has engaged with industry partners via the UK Revenue Protection Agency (UKRPA) and have created a reporting system to make it simple for meter operators to report incidents of interference to us.

WPD has strong relationships with local police and other emergency services, providing assistance on awareness courses run at Police and Fire training centres across the regions covered by WPD. The training helps the emergency services detect illegal abstraction and also ensures their safety near installations that have been tampered with.

WPD also investigate points of connection which are energised but not registered. Where a connection has become energised without a supplier, it is often very complicated to unravel the registration process and appoint a supplier. Customers in this situation have often tried to rectify the situation without success, and WPD are able to help them resolve the issue.

WPD have completed the initial review of sub-station load from information received following site inspections. This revealed estimated annual losses of approximately 5 GWh (9% increase). This has been corrected with effect from 1st July 2018.

7.3.6 Revenue Protection - Unmetered Supplies

WPD has established good working relationships with unmetered customers, in particular street lighting authorities, whose unmetered connections form approximately 90% of the total unmetered load. This involves regular group and individual meetings, which include discussions about inventory accuracy. Working closely with customers, together with the checks and balances we have in place, have provided us with a reasonable degree of confidence that unmetered system losses are minimised.

The unmetered connection agreements for larger customers, requires them to provide accurate monthly detailed inventories of all their unmetered connections. Checks are made when new inventories are loaded by WPD, to ensure there are valid reasons for records which have been removed.

WPD introduced a revised new connections process in 2016. This enables more accurate detail of the unmetered equipment to be captured, resulting in the correct calculation of annual consumptions for smaller Non Half Hourly traded MPANs. For HH traded customer MPANs, the information enables checks to be made against the larger inventories provided. The process also prevents connection dates being agreed without a valid UMS registered MPAN being recorded, therefore, minimising the risk of load being connected and not accounted for. The current estimated loss from unregistered MPANs is 20,000 kWh, which is mainly made up of MPANs created prior to the revised process being implemented.

WPD arranges regular physical street lighting audits to establish inventory accuracy. These are carried out by audit contractors and are based on a national standard, which requires the audit sample to be not less than 1% of the total inventory, subject to a minimum of 200 units. 32 audits have been carried out between 2013 to 2017 and whilst any errors found have been within metering tolerances $[\pm]1.5\%$, the results have proved useful to both WPD and customers in the pursuit more accurate records. Due to the minimal number of settlement errors found on previous physical street lighting audits, we have ceased carrying out regular pre-planned audits for the year 2018/2019. Instead, WPD would consider carrying out an audit, if the internal inventory checks warranted it. WPD have not found it necessary to carry out any audits so far this year.

In addition to street lighting audits, WPD is currently carrying out a survey of all unmetered sub-station equipment, which will enable us to validate the consumption details we have recorded.

7.3.7 Revenue Protection - Theft in Conveyance

In many cases, theft in conveyance occurs when a non-standard connection is made directly to the WPD network; or where a service to a new property is installed and connected to the network without WPD's knowledge but using 'industry standard' equipment. It is often difficult to identify these connections, especially where the property is rented and the landlord states that energy bills are included in the rental payments.

WPD works with housing groups and local authorities in this area, and find that the police awareness training often helps identify cases.

WPD has registered a scheme, under Schedule 6 of the Utilities Act 2000, which allows action to take place to recover the monetary value of units abstracted while in conveyance. WPD publishes the unit price in the statement of charges; and in addition have taken cases to court where appropriate.

In an effort to reduce theft of electricity from the network WPD is currently checking records of both MPAN and UPRN databases. By assuming all properties with a UPRN have an electricity supply and filtering out all those that correspond to MPANs, WPD is left with a list of properties without an MPAN and some of these might be unregistered connections.

7.3.8 ENA Losses Group

WPD along with all the other DNO's hold regular meetings of the ENA Technical Losses Task Group, the group has tasked the consultants WSP to conduct a project on the Impact of Low Carbon Transition on Technical Losses on the typical networks that all DNO's have, the project was completed in early 2018.

The ENA Technical Losses group have just issued a contract to WSP for producing a recommendation for a Regulatory Incentive Mechanism, this contract should be completed by Q2/Q3 2019.

7.4 Plans for 2019 and beyond

WPD plans for 2019 are to build on the work done so far and move the company's focus to new areas of potential increased losses. WPD will focus more towards low carbon technologies and, in particular, the effects of electric vehicle charging.

- Continuation of the asset replacement scheme started at the beginning of ED1;
- Electric Vehicle Charging;
- LV phase imbalance correction;
- Network Optimisation at 11kV;
- HV phase imbalance and power factor;
- Desktop studies of the LV network and customer connections using data supplied by installers of domestic solar, electric vehicle charging and heat pumps;
- Conversion of legacy networks;
- Purchase of 88 amorphous cored 25kVA 11kV low loss single phase transformers with installation and monitoring of said single core amorphous cored transformers;
- Completion of the proof of concept in using a ground source heat pump which is incorporated into the oil circuit of a primary grid transformer to provide the heat to heat up the substation buildings rather than use storage heaters;
- Substation Footprint rapid charging;
- WPD are currently working with a heat pump manufacturer to scope out a proof of concept in using a ground source heat pump which is incorporated into the oil

circuit of a primary grid transformer to provide the heat to heat up the substation buildings rather than use storage heaters.

- WPD are currently involved with Pobl and Sero Homes in producing the Housing Estate for the Future, where each house is fitted with a three phase LV service cable, solar panels, battery storage, heat pump, electric vehicle charging, smart washing machine and dishwasher all device will be programme logic controlled. The housing estate will be fully monitored on the 11kV and LV side with a view to ascertaining the losses and load balancing on a three phase connected housing estate when compared to the single phase connected houses in Losses Investigation Project on the Isle of Man, the idea being to produce an audit trail showing losses are reduced by using three phase service cables on new build properties;
- WPD are currently involved with Pobl and Sero Homes in retro fitting the Blaen-y-maes Housing Estate, where each house is fitted with a three phase LV service cable, solar panels and battery storage all devices will be programme logic controlled. As there are no driveways in Blaen-y-maes WPD will be looking to provide the cabling for on street charging hubs to be installed by third parties. The housing estate will be fully monitored on the 11kV and LV side with a view to ascertaining the losses and load balancing on a three phase connected housing estate compared to the single phase connected houses in Losses Investigation Project on the Isle of Man, the idea being to produce an audit trail showing losses are reduced by using three phase service cables on upgraded retrofitted properties;
- WPD are currently involved with Monmouthshire County Council, Wales and West Utilities and Cenex in producing a feasibility study for the Housing Estate for the Future in Caldicot, where each house is fitted with a three phase LV service cable, solar panels, battery storage, heat pump/district heating system and electric vehicle charging. The housing estate will be fully monitored on the 11kV and LV side with a view to ascertaining the losses and load balancing on a three phase connected housing estate compared to the single phase connected houses in Losses Investigation Project on the Isle of Man, the idea being to produce an audit trail showing losses are reduced by using three phase service cables on new build properties;
- WPD are currently involved with Wilson Power Transformers of Leeds to design and manufacture a 1MVA amorphous cored transformer specifically for multiple electric vehicle car charging in car parks etc. there are a number of County Councils showing interest in this concept where they are looking to install electric vehicle off street car charging hubs;
- As HV/LV losses are given as 22%, see the graph given on page 29, plus WPD have large amount of long single phase overhead lines feeding small single phase transformers and single phase transformers are outside the Eco design transformer legislation, there is a case to explore what losses could be reduced. Consequently WPD have purchased 88 single phase amorphous transformers, these transformers have Iron losses of 16W compared to the standard CRGO transformer Iron losses of 65W. Using these figures one year's cost of Iron losses for an amorphous cored 25kVA single phase transformer compared to an identical CRGO cored 25kVA single phase transformer using the following formulae show overleaf: -

No-load losses = no-load loss in watts * relevant hours.

1 Years amorphous 25kVA transformer iron losses = 140W.

1 Years CRGO 25kVA transformer iron losses = 569W.

This gives an iron loss saving of 429W per year per transformer by using the single phase 25kVA 11kV amorphous cored transformer. Using the Ofgem price of £48.42£/MWh, this equates to a cost saving of just the iron losses per transformer per year of £20.78

7.4.1 EV's and Streetlights

WPD is looking at part of the Blaen-y-maes Housing Estate project which will be supplying a dedicated three phase 4 core 300mm² Wavecon LV mains cable to street furniture / lights to overcome the issue of charging electric cars where the house holder does not have a dedicated driveway to enable EV charging i.e. terrace housing or housing association housing. In conjunction with an LV accessory supplier a new small insulation piercing connector / joint for LV mains / service cables has been designed. The use of an SNE cable would overcome earthing issues associated with CNE cable circuits.

7.4.2 Automatic LV Mains Phase Imbalance Correction

WPD are in discussions with a manufacturer to understand if it is possible to produce a dynamic means of controlling the phase imbalance on an LV mains cable. If successful a dynamic method will reduce three phase imbalance on existing LV mains cables and unit transformers compared to static means.

7.4.3 11kV Network Optimisation

From the FALCON trials undertaken, relocating 11kV NOP's to the optimum position for losses can reduce the 11kV element of losses by 8-12%, with the greatest potential saving occurring on overhead networks. WPD plans to develop this further, in conjunction with Telecoms innovations, taking into account the relative benefits of loss reduction, the capacity for new LCT connections and the Interruptions Incentive Scheme, but it should be noted that there is a balance between losses reduction in kWh's and potential Customer Interruptions with more customers on a feeder.

7.4.4 Three Phase LV Service Cables

WPD are currently involved in a losses project with Pobl and Sero Homes in producing a 250 home new build in Tonyrefail - Housing Estate for the Future, where each house will be fitted with a three phase LV service cables, solar panels, battery storage, heat pump, electric vehicle charging, smart washing machine and dishwasher all device will be programme logic controlled. The housing estate will be fully monitored on the 11kV and LV side with a view to ascertaining the losses and load balancing on a three phase connected housing estate when compared to the single phase connected houses in Losses Investigation Project on the Isle of Man, the idea being to produce an audit trail showing losses are reduced by using three phase service cables on new build properties.

WPD are currently involved in a second losses project with Pobl and Sero Homes in retro fitting circa 700 homes in the Blaen-y-maes Housing Estate, where each house is fitted with a three phase LV service cable, solar panels and battery storage all devices will be programme logic controlled. As there are no driveways in Blaen-y-maes WPD will be looking to provide the cabling for on street charging to be installed by the council / third parties. The housing estate will be fully monitored on the 11kV and LV side with a view to ascertaining the losses and load balancing on a three phase connected housing estate compared to the single phase connected houses in Losses Investigation Project on the Isle of Man, the idea being to produce an audit trail showing losses are reduced by using three phase service cables on upgraded retrofitted properties.

WPD are currently involved in a third losses project with Monmouthshire County Council, Wales and West Utilities and Cenex in producing a feasibility study for the Housing Estate for the Future, where each house is fitted with a three phase LV service cable, solar panels, battery storage, heat pump/district heating system and electric vehicle charging. The housing estate will be fully monitored on the 11kV and LV side with a view to ascertaining the losses and load balancing on a three phase connected housing estate compared to the single phase connected houses in Losses Investigation Project on the Isle of Man, the idea being to produce an audit trail showing losses are reduced by using three phase service cables on new build properties.

7.4.5 Desktop Studies of the LV network and customer connections

In WPD's ED1 plans, WPD used national forecasts to tailor scenarios for the four networks. WPD worked with the Centre for Sustainable Energy (CSE) to add socio economic factors to forecasts. For example, the numbers of electric vehicles are likely to grow in areas where the social demographic suits early adoption. This means that it is highly likely that LCT's will be clustered closely together leading to a compound effect on specific parts of the network.

For ED1 the EATL "Transform" model provided future load estimates and potential solutions. CSE has compared the output from the Transform model to socio-economic and house stock information that they hold. This has refined WPD's plans to make them more specific to local circumstances.

This work led to WPD targeted uprating of assets when other works take place over around 7% of our network, in locations where WPD could be confident of load growth.

Since 2016 WPD have been producing Distribution Future Energy Scenarios at a licence area level which predict the likely impact of EV's along with other new technologies. These forecasts show that the population of EV's is likely to match with the assumptions we made in our ED1 business plans.

7.4.6 Legacy network conversions

WPD will examine the issues of converting the legacy 6.6kV network in Bath into an 11kV network with the view to roll out on other legacy networks throughout WPD to reduce losses on the existing 6.6kV networks.

7.4.7 Substation Footprint

WPD discussing with local authorities the option to have a larger unit substation footprint this will give rise to installation of rapid 50kW electric vehicle chargers which are connected to the 11kV network to reduce losses.

7.4.8 Car Park Charging

WPD are in discussion with the some Welsh Local Authorities and transformer manufacturer to produce a “padmount” type low loss transformer which could then be used to provide an 11kV connected charging hub to cater for housing estates with only on street parking.

8 Future Considerations

There are a number of potential ways to reduce losses which rely on technology that are not yet suitably developed. As such none of these methods are likely to be implemented during RIIO-ED1, but it is important that WPD monitors them for RIIO-ED2 and beyond. Some of the methods are considered by some of the innovation projects, while others are beyond even their scope.

8.1 Superconductors

The variable losses in a network are directly related to the resistance of the current-carrying conductors. A superconductor theoretically has no resistance, which would practically eliminate variable losses in cables. Superconductors must be cooled to very low temperatures or they will still provide a resistance. Research into finding superconductors that can operate at higher temperatures is still ongoing, but as of yet none have been found which can operate above -70°C , it is unlikely they will become practical in the near future.

WPD is aware of developments in Essen, Germany where an oxide ceramic superconductor has been used to replace a 1km section of a network interconnector between two major substations. The cooling load for the superconductor must be taken into account when considering the overall loss reduction of the system. Whilst superconductors may well provide a large loss reduction in the future, it is likely that the cooling systems required will only be practical to install on very high voltage networks, perhaps only the transmission networks. But as the majority of losses actually occur on the 11kV and LV network, therefore it is unlikely superconductors will provide a beneficial solution to electrical losses in distribution.

8.2 Heat Recovery

Transformers generate heat during normal operation. Normally, this heat is lost to the atmosphere. The tendency of heat harvestry trials that have taken place has been to focus on the larger transformers with forced cooling systems.

The heat harvested from the transformers could then be sold as a commercial product to nearby customers or can simply be used to heat local substation buildings.

WPD has obtained details of a trial in Germany from an equipment manufacturer and have concluded that the end user of the heat needed to be very close, within a 10- 20m radius of our heat source. The German trial also suggested that interaction with single large heat users was more beneficial than a solution with many small domestic users.

Working with the Centre for Sustainable Energy, WPD overlaid the major substation locations on datasets from both Ordnance Survey and the National Heat Map. Where a potential user of heat was identified in close proximity to one of the substations aerial

photography was used, large scale map data and individual Heat Map Points to assess the suitability for trialling.

The results showed that out of the 1,600 major substations only 159 had nearby large customers. There were 30 which were classed as 'possible', 59 classed as 'no' and another 70 which would require more detailed investigation. National Grid work has also shown that, for their sites, heat can generally only be used at their own substation based office installations.

Although WPD have shown that a district heating system is not feasible at this time. WPD are currently working with a heat pump manufacturer to scope out a proof of concept in using a ground source heat pump which is incorporated into the oil circuit of a primary grid transformer to provide the heat to heat up the substation buildings rather than use storage heaters. (Recommendations 15, 17 & 18)

8.3 Active network configuration for losses

One way to reduce the fixed losses on the network is to switch assets off. An asset on "hot standby" (energised but not actually supplying electricity) will continue to produce fixed losses. Disconnecting duplicate or reserve assets will reduce losses but will also affect supply security and therefore has to be carefully considered before being adopted. (Recommendation 7)

WPD has analysed the impact of switching off duplicate transformers at a 33kV/11kV site, and have modelled the effect on customers by using network fault data and telecoms (SCADA) availability data. Using data from 2013, it has been concluded that the cost due to the Interruptions Incentive Scheme (IIS) of transferring customers to a "cold" transformer far outweighs the saving in losses. The implications of leaving a transformer off-line and the inconvenience to the customer of the short interruption during successful transfers should also be considered in any assessment.

WPD is continuing to monitor Low Energy Automated Networks (LEAN), the LCNF Tier 2 project being undertaken by Scottish and Southern Electricity Networks (SSEN). This project studied the effects of turning off lightly loaded primary transformers using a technique called TASS (Transformer Auto Stop Start). The project findings thus far suggest that the technique would produce beneficial results at sites which are suitable.

WPD are currently conducting their own analysis of the LEAN project using the tools provided by SSEN to assess the potential benefits of TASS on the WPD network. It has been established that in WPD out of a sample of 25 primary substations, only 1 which appear suitable and are in the process of costing the installation of equipment and undertaking a CBA to show its net worth. WPD is also concerned about the potential penalties of Customer Minutes Lost and Customer Interruptions would have significant financial swings if the technique was to fail and cause an interruption. This would easily outweigh the potential benefits.

Developments in network management systems beyond RIIO-ED1 and the increasing levels of monitoring and control will provide a platform for the reconfiguration of networks to reduce losses without the current concerns over supply security.

9 Summary & Conclusions

9.1 Summary

The traditional heart of the WPD loss-reduction programme lies in asset replacement. WPD intends to: -

- meet or exceed the Ecodesign 2015 directive with all new transformers purchased;
- oversize the 11kV ground-mounted transformers which are highly loaded enough that replacement is economically justified;
- replace the entire complement of pre-1958 ground-mounted distribution transformers;
- install a minimum size of 25kVA for single-phase pole-mounted transformers and 50kVA for three-phase units;
- discontinue 4 & 16mm² Cu. LV service cables;
- discontinue 95mm² LV Wavecon mains cables and 95mm² Al. triplex 11kV cables; and
- standardise on 185/300/400/630 and 800mm² Cu. Single core cables for the 33kV network.

WPD aims to continue working alongside suppliers to investigate transactional theft; to perform regular random audit checks in order to monitor unmetered supplies and to investigate theft in conveyance by comparing the metering records to Ordnance Survey records and investigating properties without meters.

In 2019 WPD are extending the reach of the loss reduction programme to prepare for the effect of electric vehicles and other LCT demands. WPD intends to investigate:-

- Electric Vehicle Charging;
- LV phase imbalance correction;
- Desktop studies of the LV network and customer connections;
- Conversion of legacy networks;
- Substation Footprint;
- Car Park Charging hubs;
- Three phase service cable projects;
- Three phase LV mains cable load balancing;
- Installation of 88 single phase amorphous transformers;

WPD has multiple innovation projects which are likely to lead to great advancements in network design. A lot of these advances will rely on the smart-meter roll out, which the company preparing for. By using the data from the smart meters alongside the real-time network control tools this will ensure the network is working in the most efficient manner at all times. It is envisaged that when the end of the RIIO-ED1 period is reached, it will be these network design and active network control measures that will be the focus of the loss-reduction activities.

9.2 Assessment of our Losses Performance

WPD is now at a point where most of the straight-forward actions that can be taken to reduce losses have been initiated. WPD has put the replacement of almost all assets, for which it would be economically beneficial to do so, into the policy documents, although CBA's will need to be repeated as costs and savings will change over time. WPD's shift of approach to electric vehicles will bring a new range of initiatives in the coming years.

9.3 Plans for 2019/2020

9.4 Table of Outputs

Proposal	Interventions per Annum	Savings per Annum (kWh)	Interventions through RIIO – ED1	Savings through RIIO – ED1 (MWh)
Transformers				
Replace pre-1958 transformers	250	2,694,543	1,996	21,556
Install a minimum size of pole-mounted transformer	575	68,072	4,600	545
Discontinue 315kVA ground-mounted transformers	448	1,140	3,584	9
Install low loss amorphous single phase PMT	88	38	88	114
Cables				
Discontinue small size service cables	343 km	412,629	2,744	3,301
Upsizing LV cables	694 km	3,049,799	5,552	24,398
Discontinue small size 11kV cables	448 km	951,421	3,584	7,611
Imbalance				
Correct Imbalance at LV substations	Per substation	1,014	Per substation	

Appendix 1: Progress on SOHN Recommendations

Recommendation 1: The network modelling and analysis tools used in the study are based on calibrated representative network models data. Given the increasing importance of losses, it would be appropriate that DNO's establish the capability of modelling and evaluating loss performance of their present and future networks, under different future development scenarios. **Awaiting upgrading of the computer system in 2019**

Justification: *Throughout this document, WPD have stressed the importance of modelling tools, they are vital to the understanding of losses. As such, WPD will in 2019 be updating the computer systems which will allow common software tools across the planning network to achieve this.*

Recommendation 2: DNO's to consider carrying out more systematic data gathering associated with power factor to assess the materiality of the issue and to enhance the understanding of the costs and benefits of power factor correction at consumers' premises. The business case for power factor correction may then be developed **Awaiting project information.**

Justification: *WPD currently has a project investigating the feasibility of addressing power factor issues on the 33kV network. The results of this project will help WPD decide whether more widespread power factor data gathering would be worthwhile. In addition to this all new connections to the WPD network connected via the Use of System Charges need to have a power factor of 0.95 lagging, this is to ensure that the reactive power is kept to the minimum, as with any load the DNO has to cater for the reactive power for the sizing of the circuit even though that reactive power is not being used effectively.*

Recommendation 3: Further work is required to assess the extent of the imbalance problem and to test various solutions, which will not only reduce losses but deliver many other benefits of a well-balanced network. It may be appropriate to develop policies and working practices for avoiding excessive imbalance in future. **WPD are involved in three projects in Wales where this issue will be addressed, it is envisaged that the results will then provide the audit trail for Ofgem.**

Justification: *WPD are currently involved with Pobl and Sero Homes in producing the Housing Estate for the Future, where each house is fitted with a three phase LV service cable, solar panels, battery storage, heat pump, electric vehicle charging, smart washing machine and dishwasher all device will be programme logic controlled. The housing estate will be fully monitored on the 11kV and LV side with a view to ascertaining the losses and load balancing on a three phase connected housing estate when compared to the single phase connected houses in Losses Investigation Project on the Isle of Man, the idea being to produce an audit trail showing losses are reduced by using three phase service cables on new build properties*

Recommendation 4: The inaccuracy of loss calculation using half-hourly data at the edges of the LV network should be recognised when conducting network studies. **Adopted**

Justification: *WPD has recognised this inaccuracy and has been formulating other methods to estimate loading data. The LV templates project has created a series of templates which can be used to represent different types of network areas. Having studied the load profiles of these templates carefully, they can be used to estimate the loading on other parts of the network.*

Recommendation 5: As the benefits of peak demand reduction may be material an assessment of the opportunities enabled by alternative smart grid techniques to achieve this should be carried out. **Adopted**

Justification: *WPD recognises that flattening load profiles reduces losses and as a result WPD has begun a number of investigations into how to flatten profiles effectively. The Falcon project created an automatic load transfer algorithm which used smart-meter data to determine the best way to flatten the load profile at that time. Methods using storage systems to flatten load profiles are also under development.*

Recommendation 6: As the benefits of active voltage control in LV distribution network may be significant, comprehensive assessment of the opportunities to further reduce network losses should be carried out. **Adopted**

Justification: *In the Equilibrium project, System Voltage Optimisation is being considered using a power system analysis tool. This work is still ongoing but WPD is well aware of the possible reduction in losses this could provide.*

Recommendation 7: When considering active network management solutions and technologies to facilitate low-carbon connections, the impact on losses should be given full consideration. **Under Consideration**

Justification: *WPD has considered the effects of switching off duplicate transformers at 11/33kV sites, but found it not to be beneficial due to the reduced security of supply. However, WPD is still monitoring the SSEPD project LEAN which uses Transformer Automatic Stop Start. This project has been revisited since the latest round of reporting of the LEAN project by SSEPD and a finite number of Primary substations have been identified as candidate sites and CBA's are being carried out to see if this project is viable.*

Recommendation 8: There is a clear case for fundamentally reviewing underground cable and overhead line ratings to ensure that future loss costing has been included in the economic rating calculation. This could be based on Ofgems loss investment guidelines or on loss-inclusive network design standards. **Adopted**

Justification: *In project Falcon, a dynamic asset rating was constructed. This rating was often higher than the static rating, which allows for greater network utilisation. WPD is now assessing whether to roll this out across the network.*

Recommendation 9: The transformer loss calculations indicate that the benefits of investing in low-loss transformers may be significant and this should be considered further to establish or otherwise the low-loss transformer business case in line with UK energy and carbon policy. **WPD have a project to use low loss amorphous single phase transformers.**

Justification: *In 2018 WPD have purchased 88 single phase 25kVA 11kV low loss amorphous cored transformers which exceed the 2015 Ecodesign directive, once the transformers are installed they will be monitored to ensure the losses meet expectations. From the IOM Losses Investigation project it has been found that by using **Signposting** – the HV feeder loss estimation process has demonstrated how HV feeders with high losses can be identified on the WPD HV network. These high loss feeders can then be reviewed and by replacing the old CRGO silicon core steel transformer with the new amorphous transformers, once complete to then assess the cost-benefits of loss mitigation .*

Recommendation 10: In future, losses may drive early asset replacement when economically efficient. If early replacement programmes are economically justified and capable of being funded, appropriate resources would need to be made available to facilitate delivery of such programmes. **Adopted**

Justification: *WPD has carried out extensive cost-benefit analyses on all the underground cables and transformers and have identified the cases where pro-active replacement is economically justified.*

Recommendation 11: Network designers may consider the option of installing additional distribution transformers to minimise LV network reinforcement cost and reduce losses. **Adopted**

Justification: *WPD is currently carrying out a survey of all transformers to identify any situations where losses could be reduced on overloaded transformers by adding an additional unit or uprating single units.*

Recommendation 12: In the light of future developments, particularly in relation to the integration of low carbon demand and generation technologies, it may be appropriate to reconsider long-term distribution network design. This may take a strategic view of future voltage levels and include consideration of losses in the decision-making. **Adopted**

Justification: *Distributed generation may lead to changes in network design being required. The templates created in the LV templates project include areas with a high density of distributed generation to help WPD to understand what future networks may look like. The automatic load transfer algorithms developed in Project Falcon will determine the power flow configuration which will produce the least loss.*

Recommendation 13: In order to reduce losses and provide future flexibility within LV networks, LV tapering policy may be re-examined. **Adopted**

Justification: *WPD has assessed the economic case for underground cable tapering and determined that it is never justified. It is now in the WPD policy to never taper the underground feeder cables.*

Recommendation 14: A review of DNOs' network modelling and analysis tools and capabilities may be required to support design engineers in applying new policies and processes relating to loss-inclusive network design. **Adopted**

Justification: *High quality network modelling tools are a priority for WPD as it is appreciated how important they are in aiding the understanding of the losses on the WPD network. WPD is currently in the process of upgrading the modelling tools on all parts of the network.*

Recommendation 15: There is opportunity for considerable further learning in Europe and also from National Grid. It would be beneficial to share experiences of waste heat recovery installations among DNOs. **WPD have started a proof of concept project**

Justification: *WPD are in the process of designing an installation of a ground source heat pump being inserted into a primary transformers oil cooling circuit, with the output from the heat pump being used to heat the substation buildings instead of using storage heaters.*

Recommendation 16: An Innovation Project, based upon learning from this initial Study, may be initiated in order to gather further insight into the technical and practical solutions which can be tested at more sites. The Project could be scoped to also tackle the regulatory and commercial market structural issues which will also need to be overcome to bring heat recovery and use into mainstream application. **Future Consideration**

Justification: *This is an area which is an initial topic for the ENA's Technical Losses Task Group and we will continue to work on this group to develop GB DNO's understanding.*

Recommendation 17: DNO's may maintain an awareness of the potential for heat recovery when planning the installation of EHV transformers and seek to install more systems where the recovered heat may be of commercial use. **Future consideration**

Justification: *WPD is maintaining awareness of developments in this field but it is not considered likely to be viable during the RIIO-ED1 period.*

Recommendation 18: Further work on heat storage may be integrated with future trials work on recovery of heat from the distribution network, as it may improve the economics of more basic heat recovery systems. **Future Consideration**

Justification: *The relevant technology is not yet sufficiently advanced for this to be a viable consideration. WPD is still monitoring developments and will consider an innovation project in this area when an economically beneficial outcome is probable.*

Recommendation 19: DNO's should develop loss-inclusive network design strategies, based on their specific data, in order to ensure that the overall economic network operation and design criteria are met. This should include network modelling capability for answering "what-if" questions in order to predict the impact of proposed network policies, projects and network demand forecasts on the overall reported network losses. **Adopted**

Justification: *The redesign of network modelling tools will incorporate the ability to forecast future scenarios based on different inputs today. These tools will always be used when developing future networks, to ensure WPD fully understands the long-term impact of the decisions that are made.*

Recommendation 20: DNO's, with support from DECC and Ofgem, may determine the common basis in relation to loss mitigation and loss-inclusive network design and investment. **Future Consideration**

Justification: *This is a matter that needs to be determined by Ofgem, but through the ENA's Technical Losses Task Group WPD will work alongside them to establish this.*

Recommendation 21: There is a need to establish the basis for assumptions on future electricity costs and carbon prices that would be used in loss-inclusive network investment that is consistent with the overall UK low carbon policy. **Future Consideration**

Justification: *This has partially been achieved by the Ofgem valuation of losses, but could be reconsidered to incorporate the cost of carbon produced as a result of losses. This is a matter that needs to be determined by Ofgem, but through the ENA's Technical Losses Task Group WPD would work alongside them to establish this.*

Recommendation 22: Early in the RIIO-ED1 period, DNO's may develop more accurate means of measuring and reporting of distribution network losses. **Under Consideration**

Justification: *Whilst Suppliers are currently rolling smart-meters out across the WPD network, WPD is developing the tools necessary to utilise this improved level of data.*

Recommendation 23: The DECC/Ofgem comparison of reported losses shows a discrepancy which may cause a distorted view of GB DNO losses, within industry, government and internationally. **Future Consideration**

Justification: *WPD is aware of the discrepancy between the two datasets and always refer to the Ofgem data when communicating with WPD's international colleagues. In the future, through the ENA's Technical Losses Task Group WPD will recommend to BEIS that they learn from Ofgem's correction methods, to reduce the disparity between the two datasets.*

Recommendation 24: DNO's may grasp opportunities as they may arise to influence loss reporting in other countries and as it is presented in international studies. This is in order to ensure that GB DNO's loss management performance is presented accurately. **Future Consideration**

Justification: *This is an area which is an initial topic for the ENA's Technical Losses Task Group and we will continue to work on this group to develop GB DNO's understanding.*

Recommendation 25: Industry, government and regulators should consider developing appropriate regulatory and commercial frameworks that would facilitate development of loss-generated heat schemes where economically justified. **Future Consideration**

Justification: *WPD’s early research suggests that there is very little scope of make use of heat from substations within the present frameworks. This recommendation is aimed at the regulator, but through the ENA’s Technical Losses Task Group WPD will work with the regulator to make any changes which are appropriate.*

Recommendation 26: DNO’s loss strategies may be “stress tested” to demonstrate that they can deliver an objective of achieving an economic level of losses based upon avoided loss valuation, engineering costs and future network demands. **Adopted**

Justification: *All of WPD’s strategies are thoroughly stress-tested. All of the loss-based actions and policy changes are based on thorough cost-benefit analyses and the results of actions are simulated by the network modelling tools.*

Bibliography

- [1] G. Strbac, "Management of electricity distribution network losses," Sohn Associates, 2014.
<https://www.westernpower.co.uk/docs/Innovation-and-Low-Carbon/Losses-strategy/SOHN-Losses-Report-Executive-Summary.aspx>
- [2] Stakeholder Engagement Outcomes (2016), retrieved from
<https://www.westernpower.co.uk/About-us/Stakeholder-information/Stakeholder-Reports.aspx>
- [3] F. Li, G. Shaddick, "Demonstration of LV Network Templates Through Statistical Analyses," Western Power Distribution, 2013.
[https://www.westernpowerinnovation.co.uk/Document-library/2013/LV-Network-Templates-Report-final-\(2\).aspx](https://www.westernpowerinnovation.co.uk/Document-library/2013/LV-Network-Templates-Report-final-(2).aspx)
- [4] "Network Innovation Allowance Summary Report 2015/16," Western Power Distribution, 2016. https://www.westernpowerinnovation.co.uk/Document-library/2016/WPD-NIA-Summary-15_16-Final.aspx
- [5] J. Woodruff, "Project Falcon: Close Down Report," Western Power Distribution, 2016.
<https://www.westernpowerinnovation.co.uk/Document-library/2016/SDRC-Application-FALCON-FINAL-for-publication-CLEA.aspx>
- [6] "Network Equilibrium: Interim Major Project Report," Western Power Distribution, 2016.
<https://www.westernpowerinnovation.co.uk/Document-library/2016/Jun-16-Nov-16-PPR-Equilibrium-V2F.aspx> <https://www.westernpowerinnovation.co.uk/Document-library/2016/Jun-16-Nov-16-PPR-Equilibrium-V2F.aspx>

Western Power Distribution (East Midlands) plc, No2366923
Western Power Distribution (West Midlands) plc, No3600574
Western Power Distribution (South West) plc, No2366894
Western Power Distribution (South Wales) plc No2366985
Registered in England and Wales
Registered Office: Avonbank, Feeder Road, Bristol BS2 0TB