

**CONNECTING
RENEWABLE ENERGY
IN LINCOLNSHIRE**

**LOW CARBON HUB
LCN FUND PROJECT CLOSE
DOWN REPORT**

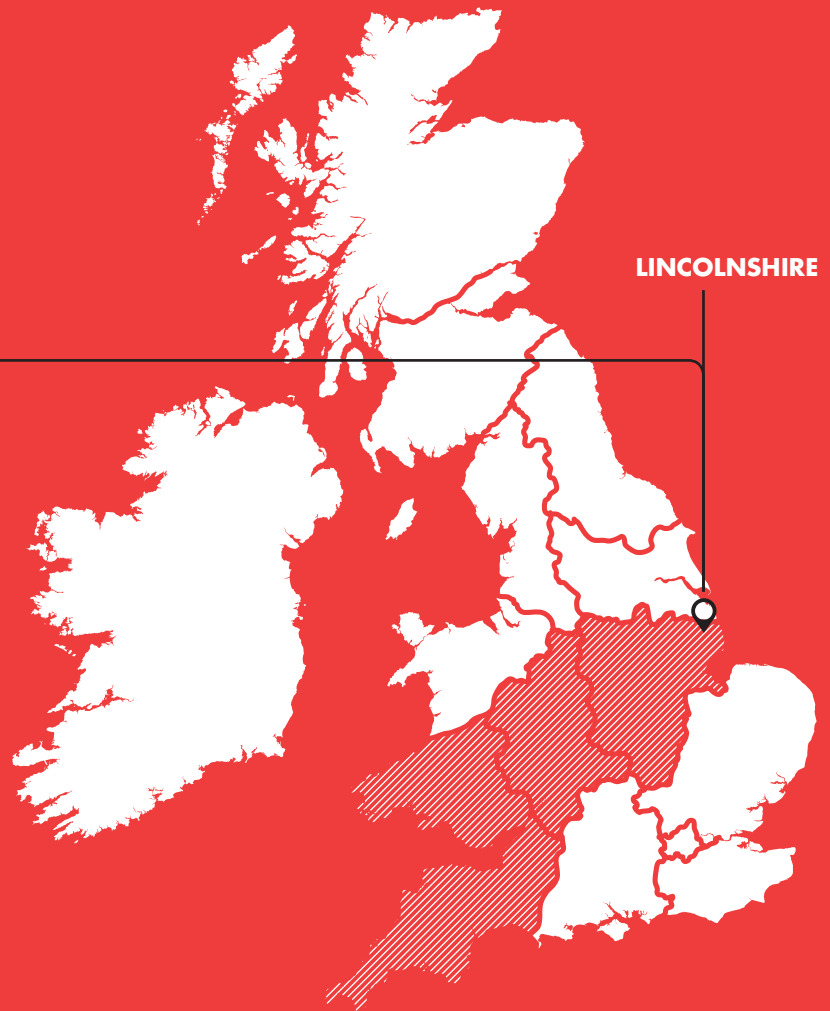

DISCLAIMER

Neither WPD, nor any person acting on its behalf, makes any warranty, express or implied, with respect to the use of any information, method or process disclosed in this document or that such use may not infringe the rights of any third party or assumes any liabilities with respect to the use of, or for damage resulting in any way from the use of, any information, apparatus, method or process disclosed in the document.

© Western Power Distribution 2015

No part of this publication may be reproduced, stored in a retrieval system or transmitted, in any form or by any means electronic, mechanical, photocopying, recording or otherwise, without the written permission of the Future Networks Manager, Western Power Distribution, Herald Way, Pegasus Business Park, Castle Donington. DE74 2TU. Telephone +44 (0) 1332 827446.

E-mail WPDInnovation@westernpower.co.uk

LOW CARBON HUB LCN FUND PROJECT CLOSE DOWN REPORT

| | |
|----------------------|----------------------------------|
| Report Title | Low Carbon Hub Close Down Report |
| Report Status | Published |
| Project Ref | CNT2002 |
| Date | 27.05.2015 |

| Document Control | Name | Date |
|-------------------------|-------------|-------------|
| Prepared by: | Philip Bale | 08.05.2015 |
| Reviewed by: | Roger Hey | 22.05.2015 |
| Approved (WPD): | Phil Swift | 22.05.2015 |

| Revision History Date | Issue | Status |
|------------------------------|--------------|---------------|
| 27/05/2015 | V1.0 | Published |

Contents

| | |
|---|-----------|
| Section 1 – Project Background | 6 |
| An Introduction to the Problem | 6 |
| An Introduction to the Lincolnshire Low Carbon Hub | 6 |
| Section 2 – Executive Summary | 7 |
| 2.1 – Project Scope, Objectives and Outcomes | 7 |
| 2.2 – Project Successful Delivery Reward Criteria (SDRC)'s summary | 9 |
| 2.3 – Key Project Learning | 9 |
| 2.3.1 – Active Network Management | 8 |
| 2.3.2 – 33kV Active Network Ring | 8 |
| 2.3.3 – Network Enhancements | 8 |
| 2.3.4 – Dynamic System Ratings | 10 |
| 2.3.5 – Dynamic Voltage Control | 10 |
| 2.3.6 – Flexible AC Transmission System (FACT) Device | 10 |
| Section 3 – Details of the work carried out | 11 |
| 3.1 – Commercial Arrangements | 11 |
| 3.1.1 – Alternative Connections – Methodology | 12 |
| 3.1.2 – Active Network Management | 13 |
| 3.1.3 – Constraint analysis software tools | 14 |
| 3.2 – Ring Network Method | 15 |
| 3.2.1 – Skegness | 18 |
| 3.2.2 – Alford | 18 |
| 3.2.3 – Bambers Wind Farm | 19 |
| 3.2.4 – Trusthorpe | 19 |
| 3.2.6 – Ingoldmells | 19 |
| 3.3 – Network Enhancements | 19 |
| 3.4 – Dynamic Line Ratings | 21 |
| 3.5 – Dynamic Voltage Control | 25 |
| 3.5.1 – Calculating voltages at key locations | 24 |
| 3.5.2 – AVC Hardware modifications to apply new voltage targets | 24 |
| 3.5.3 – Creating an algorithm and integration into software | 25 |
| 3.6 – Flexible AC Transmission Systems (FACTS) | 26 |
| 3.7 – Telecommunications | 27 |
| 3.7.1 – Optical Fibre | 28 |
| 3.7.2 – Microwave Links | 29 |
| Section 4 – Project outcomes | 30 |
| 4.1 – Commercial Agreements | 30 |
| 4.1.1 – Alternative Connections | 30 |
| 4.1.2 – Active Network Management | 30 |
| 4.1.3 – Constraint analysis software tools | 31 |
| 4.2 – Ring Method | 31 |
| 4.3 – Network Enhancements | 32 |
| 4.4 – Dynamic Line Ratings | 32 |
| 4.5 – Dynamic Voltage Control | 32 |
| 4.6 – Flexible AC Transmission Systems | 33 |
| 4.7 – Telecommunications | 33 |
| Section 5 – Performance compared to the original project aims, objectives and success criteria | 34 |
| 5.1 – Project Aims | 34 |
| 5.2 – Project Objectives | 35 |
| 5.3 – Project Successful delivery reward criteria | 37 |

| | |
|--|-----------|
| Section 6 – Required modifications to the planned approach during the course of the Project | 39 |
| 6.1 – Change to the Delivery of the LCH | 39 |
| 6.2 – Commercial arrangements | 39 |
| 6.3 – Change to the delivery of the Ring Method | 39 |
| 6.4 – Network Enhancements | 41 |
| 6.5 – Dynamic Line Ratings | 41 |
| 6.6 – Dynamic Voltage Control | 41 |
| 6.7 – Flexible AC Transmission Systems | 41 |
| 6.8 – Telecommunications | 41 |
| Section 7 – Significant variance in expected costs | 42 |
| Section 8 – Updated Business Case | 44 |
| 8.1 – Commercial arrangements | 44 |
| 8.2 – Ring Method | 44 |
| 8.3 – Network Enhancements | 45 |
| 8.4 – Dynamic Line Ratings | 45 |
| 8.5 – Dynamic Voltage Control | 45 |
| 8.6 – Flexible AC Transmission Systems | 45 |
| Section 9 – Lessons learnt for future Innovation Projects | 46 |
| 9.1 – Commercial arrangements | 46 |
| 9.2 – Ring Method | 46 |
| 9.3 – Network Enhancements | 47 |
| 9.4 – Dynamic Line Ratings | 47 |
| 9.5 – Dynamic Voltage Control | 47 |
| 9.6 – Flexible AC Transmission Systems | 47 |
| Section 10 – Project replication | 48 |
| 10.1 – Commercial arrangements | 48 |
| 10.2 – Ring Method | 49 |
| 10.3 – Network Enhancements | 49 |
| 10.4 – Dynamic Line Ratings (DLR) | 49 |
| 10.5 – Dynamic Voltage Control (DVC) | 49 |
| 10.6 – Flexible AC Transmission Systems | 50 |
| 10.7 – Telecommunications | 50 |
| 10.8 – Commercial arrangements | 50 |
| 10.9 – Ring Method | 51 |
| 10.10 – Network Enhancements | 51 |
| 10.11 – Dynamic Line Ratings (DLR) | 51 |
| 10.12 – Dynamic Voltage Control (DVC) | 51 |
| 10.13 – Flexible AC Transmission Systems | 51 |
| 10.14 – Telecommunications | 51 |
| Section 11 – Planned implementation | 52 |
| 11.1 – Commercial arrangements | 52 |
| 11.2 – Ring Method | 52 |
| 11.3 – Network Enhancements | 53 |
| 11.4 – Dynamic Line Ratings | 53 |
| 11.5 – Dynamic Voltage Control | 53 |
| 11.6 – Flexible AC Transmission Systems | 53 |
| 11.7 – Telecommunications | 53 |
| Section 12 – Learning dissemination | 54 |
| Section 13 – Key Project learning documents | 56 |
| Section 14 – Contact details | 57 |

Section 1 – Project Background

In 2010, the UK Government committed to reduce greenhouse gas emissions by at least 80% by 2050 relative to the 1990 emission levels. In order to reach this carbon reduction, an interim target of 15% of electricity generated from renewable sources was set for 2020. Since then, a number of incentive schemes including Renewable Obligation Certificates (ROCs), Feed-in-Tariffs (FITs) and more recently Contracts for Difference (CfDs) encouraged a large number of new renewable generation connections to distribution networks. However, the surge of new connections caused a number of network problems, so the Low Carbon Hub (LCH) project was developed and funded through the Low Carbon Networks Fund (LCNF) to demonstrate quicker and more cost effective ways to connect generation.

An Introduction to the Problem

Distribution networks at all voltage levels, from 132,000V down to 415V, have predominately been designed for demand connections and to operate passively. This passive design philosophy has historically been the most appropriate and cost effective method to operate distribution networks since the difference between minimum and maximum network demands hasn't been significant. When network reinforcement was required, for a proposed increase in either demand or generation, this was largely achieved through installing new overhead lines (OHL) and / or underground cables.

However, due to the increasing connection of distributed generation, large areas are becoming generation dominated and, at times when the generated energy exceeds demand, power is exported from the distribution network back into the transmission network. This can cause problems on both the distribution and transmission networks which restrict further generation connections.

An Introduction to the Lincolnshire Low Carbon Hub

The Low Carbon Hub for East Lincolnshire has been designed to test a variety of new and innovative techniques for integrating significant amounts of low carbon generation on to electricity distribution networks, in an effort to avoid the costs and other issues that would normally be associated with more conventional methods of network reinforcement.

Lincolnshire, being on the east coast, makes it suitable for a wide range of renewable generation types. These include onshore and offshore wind farms, large scale solar Photo Voltaic (PV) and energy from bio crops. However, many generators cannot connect to the distribution network closest to them due to the effects their connection would have on the operation of the existing network. These generators thus tend to require long, new underground cable installations to connect them to more robust sections of the network. This is inevitably a very expensive solution that frequently destroys the business case for the generator. However, Western Power Distribution (WPD) has continued to receive a high volume of connection enquiries from developers throughout the life of the LCH – a situation that has strengthened the justification for this project.

Through the Low Carbon Hub, the project sought to explore how the existing electricity network could be developed ahead of need and thus deliver low carbon electricity to customers at a significantly reduced cost in comparison to conventional reinforcement.

The project has developed the six complementary project techniques detailed in Figure 1, demonstrating them and a telecommunications system in east Lincolnshire to increase effective network capacity and facilitate additional generation connections. To help with this objective, the project received £3m of funding from Ofgem's Low Carbon Networks Fund Tier 2.

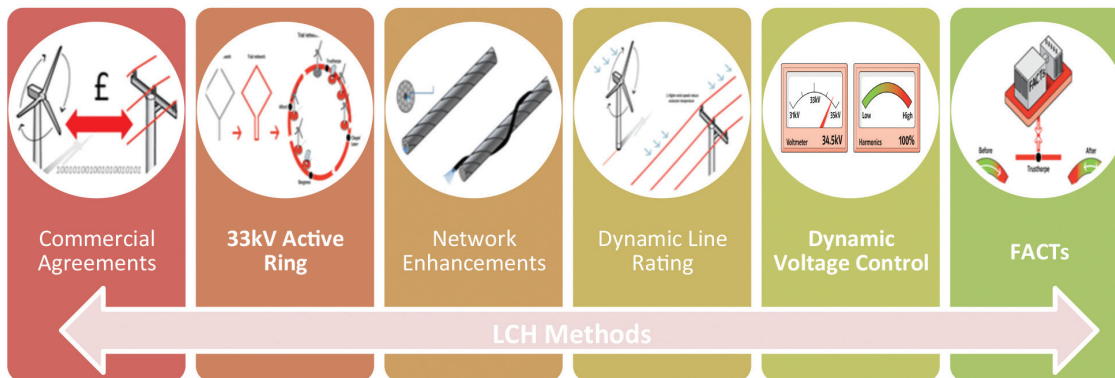

Figure 1 – LCH Methods

Section 2 – Executive Summary

The UK Government's introduction of the Renewable Obligation Certificates, (ROCs), Feed-in-Tariffs (FITs) and Contracts for Difference (CfD) schemes has accelerated the network connections of a diverse mix of renewable generation types, often to the 11,000V or 33,000V distribution networks. As a result, distribution networks – that have been designed for, and operate well in the role of, distributing electricity to customers – are now being asked to also play the reverse role, that of collecting electricity from generators distributed around the network and delivering it to the high voltage national grid. This distributed generation function has risen from 500 MVA in November 2010 to 1700 MVA in February 2015. Further committed connection applications are likely to take this figure to above 4850 MVA in the coming years.

The first distributed generation (DG) connections in an area were usually relatively easy to implement, but technical issues of the network design meant that later connections in these same areas became increasingly costly and complex to accommodate. East Lincolnshire was one of the first areas in East Midlands where, since 2010, the majority of further generation connections could only be achieved if significant, cost prohibitive conventional network reinforcement was carried out first.

The issues first seen in East Lincolnshire are now occurring across many other areas, especially within Western Power Distribution (WPD)'s East Midlands, South Wales and South West England licence areas. These networks, like East Lincolnshire, are increasingly offering prohibitively expensive generator connections, and require more cost effective methods to facilitate new (DG) connections.

This project has designed and trialled six methods of providing these cost effective connections. Their aim is to practically unlock additional DG capacity within the East Lincolnshire network. A measure of success of the project is that it has already facilitated an additional 48.8MVA of new generation connections using some of the new innovative methods trialled.

2.1 – Project Scope, Objectives and Outcomes

The Low Carbon Hub had the following Scope and principal Objectives:

- Create an active smarter design and operate the network in a way that will allow generation to be connected to the distribution network more economically. This will allow the most suitable generation sites to connect to the network,
- Develop a distribution network optimised for demand and generation whilst demonstrating solutions to some of the network limitations,
- Increase visibility and control of the 33kV system and reduces emitted carbon from technical network losses, and
- Demonstrate previously unproven high voltage network assets.

The scope and objectives were met through the design and application of six 'methods', all demonstrated in East Lincolnshire.

2.1.1 – New commercial agreements



The Low Carbon Hub project (LCH) has demonstrated how Distribution Network Operators (DNO) and generation developers can enter into new innovative commercial arrangements, now referred to as Alternative Connections Agreements. These agreements can unlock additional generation capacity if the generator is willing to operate in a suitable reactive power control mode and to constrain active power export when required. Western Power Distribution (WPD) has been offering cost-effective HV and EHV Alternative Connection Agreements in East Lincolnshire since February 2014 as an alternative to the high cost of conventional network reinforcement. Six Alternative Connections have been accepted, allowing the connection of 48.8MVA of additional new connections at an estimated cost saving of £42m.

For the new commercial agreements method to succeed, the project also required hardware –an Active Network Management (ANM) scheme to monitor key network points and to constrain the power export of Alternative DG Connections at times when, otherwise, the network would operate outside of its design and statutory limits. The ANM scheme has been installed and integrated into WPD's Network Management Software (NMS). This can facilitate the cost effective connection of generation by preventing the less likely, but extreme, system operation scenarios that trigger network reinforcement.

Finally, the project required new network planning skills to understand the impact of Alternative Connections on the network under both normal and abnormal network conditions. Two new constraint analysis software tools were thus specified, designed, tested and used by WPD planners as part of the project. These planning tools provide greater visibility of the network power flows after Alternative Connections have been made. WPD notes that DG developers also need to understand whether an Alternative Connection is suitable for them by performing their own due diligence on the connection and likely future constraints.

2.1.2 – 33kV active network ring

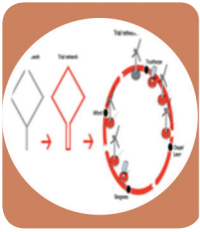

The creation of the ‘active network ring’ allows the network to run with greater controllability. This is possible through increased visibility of power flows and voltage profiles. The arrangement allows the system to be reconfigured, based on the real time status of the network, to optimise system capacity under system stress, which involved installation of new network equipment. Extensive network construction and reconfiguring was carried out at 6 substations to allow two network feeders to be meshed.

This arrangement also increases power flow route diversity, with the associated benefits to system availability and losses reduction.

2.1.3 – Network enhancements



One of the LCH methods was to ascertain what additional functionality should be either designed or built into networks to reduce the costs of connecting future generation. In this trial, key overhead lines (OHL) that were already being replaced for asset condition reasons were given enhanced capacity specifications, and 300mm² Hard Drawn Aluminium (HDA) conductors were fitted in place of the original 150mm² steel reinforced aluminium conductor (ACSR). 10.2km of 33kV network was rebuilt with the larger design standard.

This double cross-sectional area offered half the circuit resistance. Reducing the circuit resistance in this way unlocked additional network capacity for both conventional and alternative connections, and reduced technical losses.

The project required low latency, high bandwidth telecommunications links between primary substations for network protection and other data requirements. All suitable technologies were investigated and reported on in a review of the available wired and wireless communications media.¹ Fibre and microwave comms networks were installed as part of the project.

¹ www.westernpowerinnovation.co.uk/documents.aspx

2.1.4 – Dynamic system ratings



The LCH built on the work of the Skegness 132kV Dynamic Line Rating project in the Registered Power Zone (RPZ) which delivered cheaper connections to the offshore wind farms, giving Western Power Distribution Policy for dynamically rating 132kV tower lines. The LCH has developed a method of dynamically rating 33kV OHLs. This approach uses new code within the NMS to calculate maximum operating limits for the 33kV OHL based on real time electrical output of wind farms instead of using multiple weather stations.

The method converts the electrical output from multiple turbines into the wind speed at the nacelle height using turbine manufacturer’s data. The wind speed at the OHL height is then estimated using the wind shear power law. Finally the wind speed data is incorporated into the Dynamic Line rating algorithm to better estimate the actual maximum circuit rating, thus making best use of all the available information.

2.1.5 – Dynamic Voltage Control

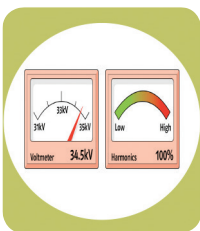

Dynamic Voltage Control (DVC) algorithm, has been incorporated within WPD’s Network Management Software (NMS). It optimises the network voltage using key voltage and current measurement points across the East Lincolnshire network. Both existing Automatic Voltage Control (AVC) relays at Skegness Grid Substation and communications infrastructure have been modified to accept automated remote target voltage changes directly from the NMS. The DVC method can optimise the voltage profile very effectively balancing both demand and generation requirements to unlock capacity.

This element of the LCH project even manages to create an effective data monitoring point where there is no instrument transformer. At Horncastle Primary substation, the DVC requires a 33kV primary voltage measurement. Since there is no 33kV VT, an equivalent signal is being derived from measured values for the 11kV voltage, the real and reactive power through the transformer, its tap position and the transformer’s physical characteristics.

2.1.6 – Flexible AC Transmission System (FACT) Device



One of the factors that would unlock further network capacity is an improved control of power factor and network voltage. One method of controlling these parameters is to provide (source or sink) shunt compensation through an appropriate shunt-connected device.

One such device is a DStatcom, so the LCH project procured a 3.75MVAR DStatcom for this purpose. It was connected in parallel with the electricity network at Trusthorpe to improve the control, locally, the power factor and network voltage. Through this LCH project the solution was demonstrated for the first time in mainland UK at 33kV. The DStatcom can control the network voltage (boosting the voltage by 3% and bucking the voltage by as much as 5%) and can reduce network losses by balancing circuit reactive power flows.

2.2 – Project Successful Delivery Reward Criteria (SDRC)’s summary

The LCH Project has managed to achieve all of the project aims and successful delivery criteria as stated in the latest direction issued by Ofgem on the 20/11/2013. A full copy of the evidence for each SDRC is detailed in section 5.

| Successful delivery reward criterion | |
|---|---|
| SDRC 1) Host a successful workshop with Distributed Generation developers and feed learnings into the project plan. | ✓ |
| SDRC 2) Development of a UK technical recommendations for: <ul style="list-style-type: none"> 1) Installing optical fibre on existing wood pole OHL; 2) Installing optical fibre on new wood pole OHLs; 3) Installing microwave or radio antennas and associated equipment within the proximity of distribution assets including the configuration of equipment for effective system protection. | ✓ |
| SDRC 3) Completion of the first application of dynamic system control and operation using GE PowerOn Fusion. | ✓ |
| SDRC 4) Determining the degree to which voltage can be controlled by installing and operating a FACTS device. In particular, ascertain whether the device improves quality of supply to demand customers and/or improves generator network availability. | ✓ |
| SDRC 5) Development of a stronger relationship with distributed generation developers directly impacted by the LCH. | ✓ |
| SDRC 6) The capture of sufficient information to determine the business case for operating active 33kV ring networks using innovative solutions. | ✓ |
| SDRC 7) Disseminate knowledge and evaluate the potential for similar projects throughout the UK. | ✓ |

Table 1 – Successful delivery reward criterion

2.3 – Key Project Learning

2.3.1 – Active Network Management

After a successful demonstration, Active Network Management will continue to be rolled out by WPD across all four WPD licence areas with 11 new zones opened by 2023. Each will use the Alternative Connection agreements developed as part of this project. An extensive internal implementation programme is required to make an ANM rollout possible.

A DNO constraint analysis tool is an essential aspect of Alternative Connections for both the DNO and DG developer. The project has built and demonstrated how a constraint estimation tool can be used to study Alternative Connections under both normal and abnormal network configurations, how a generation developer can be provided with the necessary information to evaluate likely constraints, understand the risk and suitability of accepting an alternative connection.

2.3.2 – 33kV Active Network Ring

The project has shown the 33kV active ring method is less appropriate than ANM for roll-out due to the high costs and effort associated with delivery, and the low net benefit. It is expected that, for simple meshing scenarios, benefits could be achieved by adapting the existing network more cost effectively. For more complex meshing scenarios, an offline rebuild would be most appropriate solution. Further work is required to understand when it is appropriate to mesh simple 33kV sections.

The project aimed to show how the existing network could be altered rather than rebuilt to enhance capacity. The learning has shown that if the delivery timescales are short and significant works are required on site, the quickest solution is the construction of an offline build as demonstrated at Trusthorpe primary substation. This approach also reduces network risk as the majority of the construction can be carried out away from high voltage network and whilst the existing network is still in service. The use of a hybrid of existing air insulated assets and new gas insulated switchboards connected with cables has to be carefully managed to prevent the operation of sites being too complex. This was carefully managed within WPD’s existing design policies.

2.3.3 – Network Enhancements

Certain assets, such as 33kV OHLs in ANM areas, should be enhanced ahead of need where there is a clear indication the functionality will be utilised in the future. The installation of a larger conductor reduces the resistance of the circuit; the reactance of the replacement circuit remains similar to the original circuit. The replacement conductor reduced the effects of voltage drop and voltage rise and reduces network losses.

It can be challenging to secure landowner permission if trying to replace an OHL with shorter span lengths. As this was achieved with a new OHL H pole design with an equivalent span of 145m. This can be used again for similar future scenarios.

2.3.4 – Dynamic System Ratings

We have learnt how an algorithm can be scripted within WPD's NMS using Wind Farm output as a proxy for wind speed. Dynamic Line Ratings must take into account all the assets in a circuit such as cables, circuit breakers, disconnectors and current transformers which cannot be dynamically rated based on weather conditions, their ratings are fixed. In East Lincolnshire, the 33kV OHLs can typically be dynamically rated up to 113% of the static winter rating. Any further increase would require cables and current transformers to be uprated. The DLR must also apply the safety factors that are required to account for any sheltering of a line. Both natural and manmade structures can cause sheltering and change over a relatively short time period.

2.3.5 – Dynamic Voltage Control

Networks voltage profiles can be optimised by using centralised network intelligence. A control algorithm can be located within a NMS with remote target voltages applied to AVCs using an algorithm to determine whether the network voltage can be safely adjusted taking into account both the present demand and generation conditions. Further work is required to make this a more robust and failsafe method before roll out across a wide area.

Transferring an AVC relay across to DNP3 control will unlock additional functionality in the relay; however this requires numerous changes across the business outside of a trial.

An AVC relay can be cost effectively used to provide a steady state voltage measurement where there isn't a voltage transformer.

2.3.6 – Flexible AC Transmission System (FACT) Device

A DStatcom, a FACTS device, is very effective at controlling voltage, especially during network outages to remain within statutory limits. On relatively weak networks, at the ends of feeders, or at relatively long electrical distances from the voltage controlling substation, it is particularly effective.

- When the DStatcom is operating at 100% capacitive mode (exporting reactive power) the voltage is boosted by 3%.
- When the DStatcom is operating at 100% reactive mode (importing reactive power) the voltage is reduced by 5%.

Where there are both voltage rise and drop issues, Statcoms will increasingly be used in key distribution locations to improve voltage control and to facilitate further generation connections. The WPD DStatcom complies with WPD's noise policies, however unless additional noise mitigations are put in place – the audible noise generated by a DStatcom is likely to limit their use in substations in close proximity to customers.

Section 3 – Details of the work carried out

Connection efficiency enhancing methods trialled by this project

This section details the delivery of the six project techniques and the telecommunications system installed as part of the LCH. Changes to the original planned approach and the associated change request are detailed in required modifications (Section 6).

3.1 – Commercial Arrangements

Overview

The development of new, more versatile, commercial agreements that benefit both the generators and WPD and allow additional usage of the existing network.

Background to Existing Distributed Generation Connections

Historically, DG connections have been either of the non-firm teed connections variety (the vast majority), or of the much more costly firm “looped” connections, where the associated network has two separate routes and the connection is designed to operate under most fault and outage conditions. The LCH project trialled a connection design that unlocks additional capacity within a network, often at significantly reduced using an innovative control scheme, to provide an often cost effective, alternative to conventional connections.

Low Carbon Hub – Commercial Arrangements Work Carried Out

The LCH project has explored how new innovative commercial arrangements between DNO and generation developer can unlock additional generation connection capacity on the network in a cost-effective manner whilst ensuring networks continue to operate within their design and statutory limits. This work has been a great success and, Since February 2014, for generators in East Lincolnshire who are willing to operate in a reactive power control mode and constrain active power output, WPD has been offering what is now termed Alternative Connections instead of cost prohibitive conventional network reinforcement.

To achieve this, the project had to address the following three elements:

- Research on constraint methodologies, engaged with customers and made amendments to the standard connection agreements, creating an attractive suite of Alternative Connections agreement documents,
- Specification, design, procurement and installation of an Active Network Management scheme in East Lincolnshire that remotely constrains the real and reactive power output from DGs during periods when the network cannot absorb the excess generation,
- Specification, design, and testing of two new planning tools called constraint analysis software tools. These help WPD planners understand the impact of Alternative Connections on the network under both normal and abnormal network conditions. They also provide new DG developers with an understanding of the constraints a new development might have experienced in the past to promote their understanding of how the constraints may change for a number of difference sensitivities.

The details and methodology for Alternative Connections, Active Network Management and Constraint Analysis software tools are described in more detail below. Figure 4 shows the project plan for the delivery of the commercial arrangements.

In developing WPD's Alternative Connections, discussions were held with both SSE and UKPN to help coordinate the development and trials of new commercial agreements as part of innovative projects. Importantly, these discussions also helped us and these other DNOs benefit the customer by standardising on new commercial terms and language. The direct feedback from the DNOs and wider stakeholders at WPD's commercial agreements dissemination events supported this approach. The new definitions and key terms are detailed in the outcomes of the project (Section 4) and are explained in Appendix B.

Following research through workshops and other consultation (see Appendix B), Engage Consulting recommended functional changes to the Connection Agreement letter and Connection Offer letter.

External Legal Review of New Documents

The project team amended standard HV and EHV connections documents to take into account the changes required for Alternative Connections. Osborne Clarke, WPD's legal advisors, reviewed the offer letters and connection agreements and provided comments. Blank copies of the resulting HV & EHV Section 15 and 16 offer letters and connection agreements, as of February 2015, can be found in Appendices C and D.

3.1.2 – Active Network Management

The second element of the creation of WPD's Alternative Connections package was to establish Active Network Management. The UK's first demonstration of Active Network Management (ANM) was installed on Orkney as part of a Registered Power Zone (RPZ) to manage thermal limits. WPD met with SSE to discuss the lessons learnt from the Orkney demonstration before embarking on Active Network Management for East Lincolnshire. The ANM zone in East Lincolnshire represented a substantial leap forward in ANM design due to the complexity of nested voltage and thermal constraints at all voltage levels there.

We then carried out a series of network studies to identify the key network parameters within the ANM area which required monitoring. This was done through existing current and voltage transformers in real time.

- Thermal constraints on the 132kV double circuit from Skegness – Boston – Bicker Fen;
- Transformer constraints on Skegness 132kV/33kV GT1 & GT2;
- voltage and thermal constraints on Selected East Lincolnshire 33kV circuits; and
- voltage and thermal constraints on Selected East Lincolnshire 11kV circuits.

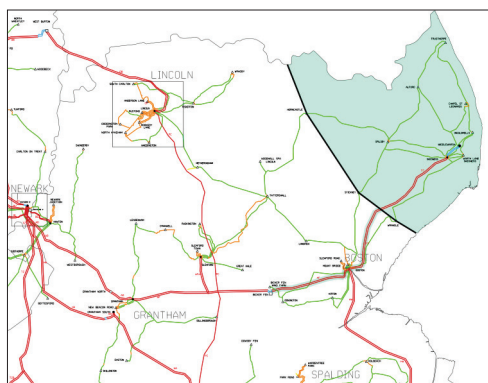

Figure 5 ANM network diagram 132kV & 33kV network area

An ITT was issued for the production & installation of the ANM scheme and three companies responded. The evaluation criteria covered technical fit, service levels, delivery, financial and commercial aspects and an ANM contract was awarded in October 2013. The factory acceptance test (FAT) was passed in March 2014 and installation occurred in Skegness and WPD's Pegasus offices between March – April 2014. Appendix E contains WPD's Active Network Management specification for tender; technical details and details the installation process.

The first DG developer to accept an Alternative Connections Agreement applied for a connection at the end of May 2014. Four sets of 132kV and 33kV assets were identified as key constraint points requiring real time monitoring for this connection.

The ANM monitoring system has been configured to constrain the associated generators' output in a LIFO methodology (as described in the commercial report in Appendix B) when key voltage or thermal limits are reached. When a constraint condition no longer exists, the ANM equipment dispatches the Alternative Connected generation, filling the spare capacity that exists within the network. Each key network parameter has an associated Reset, Trim, Sequential trip and Global trip value to ensure the network operation remains within acceptable limits. Figure 6 below shows how the limits are set below the maximum power flow for a thermal restriction. Pre-determined sensitivity factors are assigned to each generator which dictates the level of response that is required from the generator.

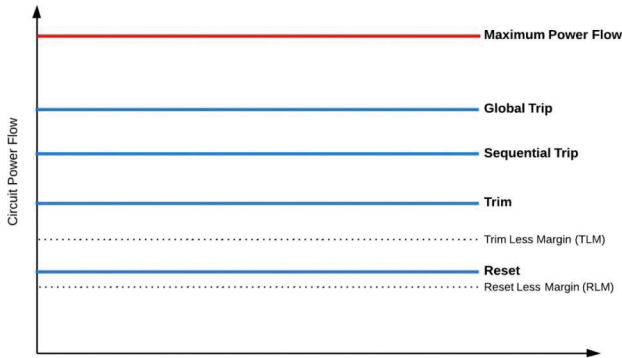

Figure 6 – ANM principles for unlocking capacity

The ANM equipment was first installed in Skegness Grid Substation and later relocated to a server room in WPD's Pegasus office where it has been integrated within WPD's Network Management System (NMS) PowerOn¹ Fusion to provide further visibility and control of the Alternative connections across the LCH. Figure 7 is a schematic configuration of the East Lincolnshire ANM scheme. Details of the integration of the ANM scheme into WPD's NMS are included in Policy OC18 – Active Network Management.

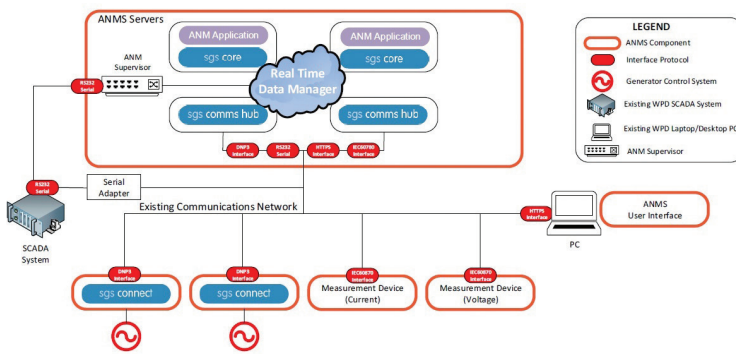

Figure 7 – Active Network Management scheme installed for the East Lincolnshire Network

3.1.3 – Constraint analysis software tools

The third and final element of the creation of WPD's Alternative Connections package in East Lincolnshire was for us to be aware, real time, of the power flows and voltages across the distribution network when the ANM scheme is operating. Potential new generation customers need to be aware which parts of the distribution network have limiting factors. Potential constraints will change throughout the year depending on the demand profiles at each primary substation and the number, type, location and size of proposed generation connections.

The constraint estimation tools have been used by both customers and WPD as part of the Lincolnshire Low Carbon Hub to facilitate the connection of additional generation using Active Network Management.

¹PowerOn Fusion is WPD's NMS provided by GE. Control Engineers use PowerOn to manage the connectivity and configuration of HV and EHV network assets

TNEI developed both the desktop and web based software tool around our existing power flow analysis models, using ½ hourly historical demand and generation profile data between January 2011 to June 2014. Sequential power flows studies are run for all nodes in the Skegness network from the Bicker Fen Super Grid Transformers to each 11kV primary busbar. If the model detects any exceedance of thermal or voltage limits across the network, the last generator on the LIFO queue is constrained by 10% and the model is re-run until the network model remains within limits. Full details on the Functional Specification, design and build of the constraint analysis tools are detailed in the LCH Constraint Analysis Tool Close out report in Appendix F.

Desktop tool

The constraint analysis tool built for Western Power Distribution’s Primary network planning team requires the planner to specify the new point of coupling for the generator and connection length between the generator and the existing network. The tool has been installed on laptops and desktop computers allowing WPD’s primary system designers to identify the network constraints under different abnormal network scenarios. The tool uses a standard IPSA 2 licence.

Web based tool for generation developers

In the interests of customer service, a simplified constraint analysis tool (using the same data and algorithm as the desktop version) has also been created for generation developers. It was designed to provide a high level evaluation of potential constraints on new developments at different points on the network before investing too much time and effort into the development of a new site. The constraints analysis tool has been hosted at www.lincolnshirelowcarbonhub.co.uk and uses a simple graphical interface. It does not require any knowledge of primary system design or power flow analysis software. Appendix F shows the Web based tool user interface and the results sheet from the desktop tool, which indicate how easy it is for customers to use.

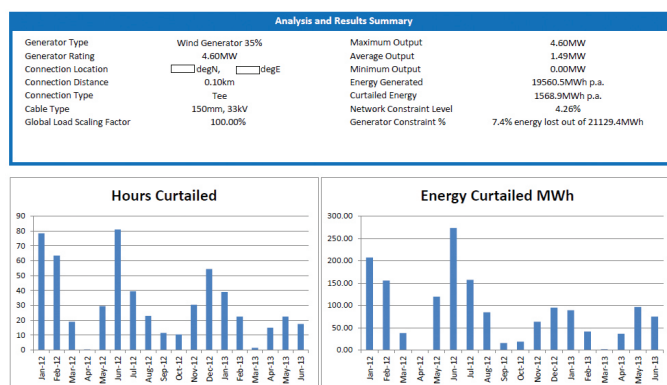

Figure 8 – Screen Shot of Web tool & Desktop tool Results Summary

3.2 – Ring Network Method

Overview

Enhanced network capacity through the improved versatility and controllability of ring network configurations.

Background

33kV distribution networks in rural areas largely comprise radial feeders supplying two-transformer primary substations. The existing network in the area around the LCH follows this pattern. It includes radial feeders running from Skegness to normally open points at Trusthorpe, Chapel St Leonards and Ingoldmells primary substations (as seen in Figure 9). This radial network configuration is relatively simple to operate and maintain because power can only flow along one path. However the connection of additional generation to radial networks can result in voltage rise and thermal constraints² on the system. Voltage rise occurs when Distributed Generation (DG) is connected to the network and power flows in the opposite way to that originally anticipated.

²Constraint is the term applied to a voltage or thermal limitation which a generator is curtailed against

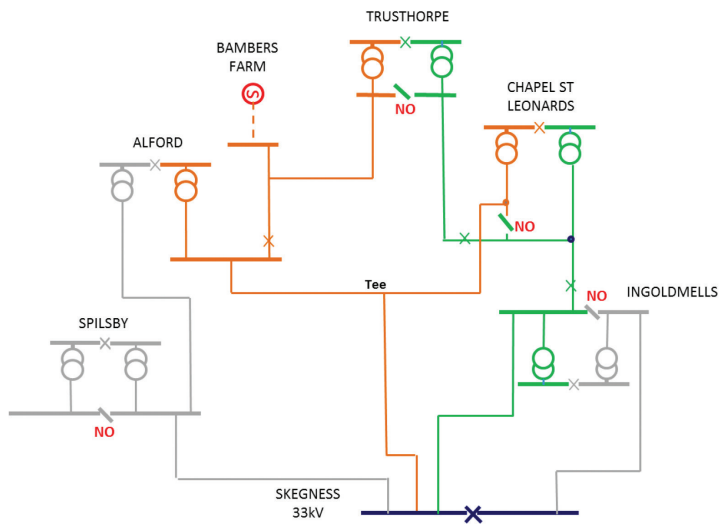

Figure 9 – Existing Network Layout (2 Radial Feeders) with Normally Open (NO) points

Meshing feeders (that is, closing the normally open connections) has been shown to increase the capacity of networks. The Scottish Power Manweb network was designed to operate with a high degree of meshing; and meshing feeders also features in the transform model for 11kV networks as a method of increasing network capacity. However, modifying an existing radial network to a meshed operation is not always as straight forward a proposal as it initially appears. With the East Lincolnshire rural network, concerns were increased around the protection discrimination due to low fault levels, significant reverse power flows from inverter sourced generation and the use of dynamic shunt compensation.

Low Carbon Hub – Ring Network – Work Carried Out

The creation of the ‘active network ring’ involved installing additional switchgear, disconnectors, cables, new telecommunication links and new protection relays. Figure 10 show the project plan for the delivery of the Ring Network.

LOW CARBON HUB LCN FUND PROJECT CLOSE DOWN REPORT



Figure 10 – 33kV active network ring project plan

The following summarises the work was carried out at each site by WPD’s Projects team with support from specialist contractors – and further details are available in Appendix G.

3.2.1 – Skegness

- System security improved, and power flows balanced (through 33kV circuit transposition);
- Several new back-up protection systems provided; and
- 110V batteries and charger capability increased.

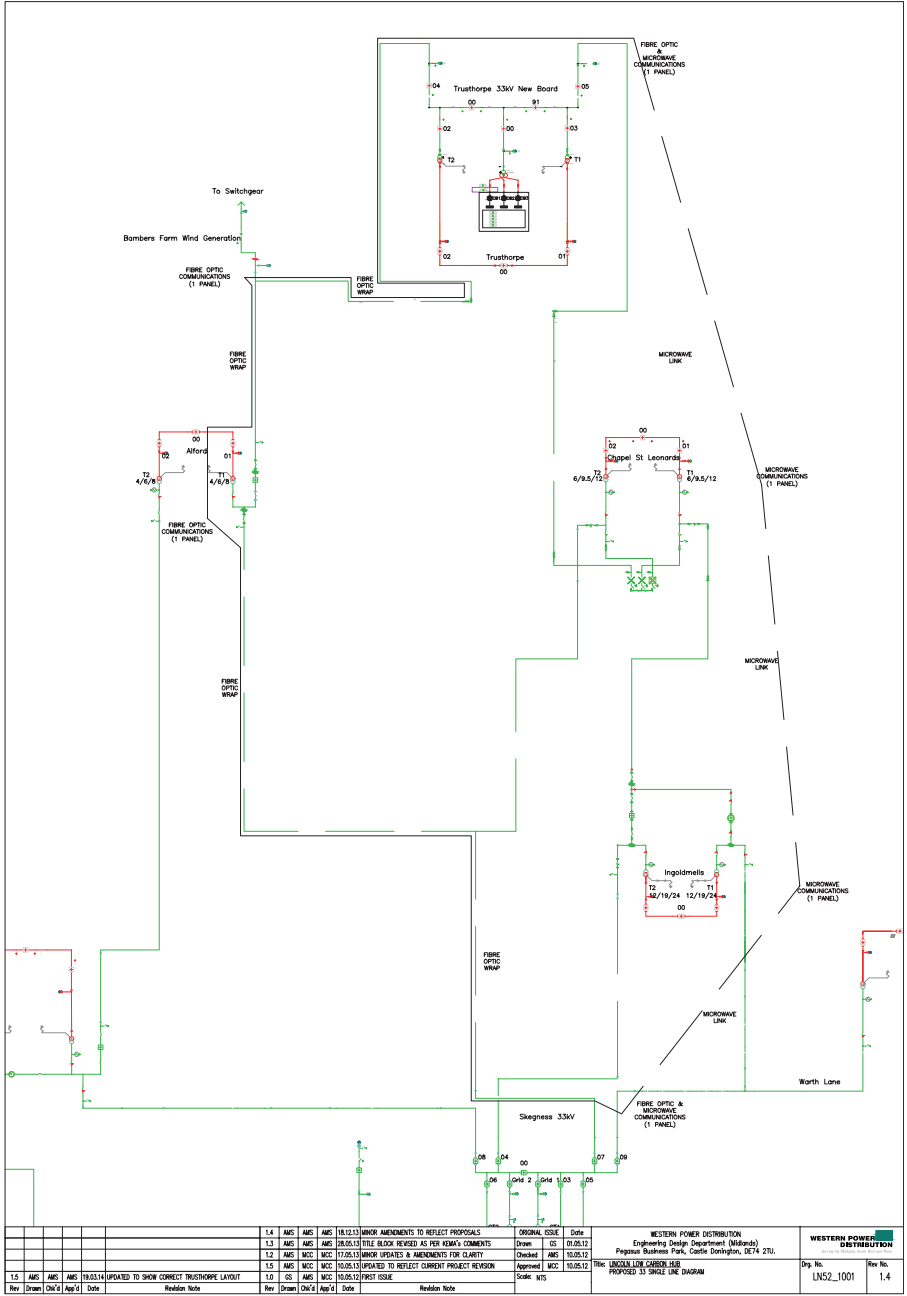

Figure 11 – Single Line Diagram Ring network

3.2.2 – Alford

- New CTs and VTs were provided;
- Equipment was changed in order to obtain appropriate auxiliary contacts; and
- New protection systems were provided.

3.2.3 – Bambers Wind Farm

- Instrument transformers and protection was added at this site.

3.2.4 Trusthorpe

- A new 33kV 7 panel switchboard and new protection was added at this site.

3.2.5 Chapel St Leonards – (As shown in Figure 12)

- A new 33kV 3 panel switchboard, VTs, and new protection was added at this site.



Figure 12 – Chapel St Leonards Installation – cable connections shown left of centre.

3.2.6 – Ingoldmells

- New bay to with additional circuit breakers installed;
- Up-grades included a new circuit breaker and new line disconnectors;
- VTs and new protection were also added.

The installation of the new plant at all these sites allows the network shown in Figure 11 to run as a closed ring. Through increased visibility of power flows and voltage profiles, this offers greater controllability and network flexibility, allowing network reconfiguration based on its real time status. The protection scheme operates under normal conditions using the new communications network described in the telecoms section. The backup protection, when the communications are not operational, is distance protection or directional overcurrent.

3.3 – Network Enhancements

Overview

During network reinforcement design, the cost-effective increase of network capacity beyond that which is strictly required for current purposes.

Background

The design of the primary network and asset replacement programme is influenced by a number of factors:

- the amount of demand a network area must support when operating both normally and abnormally (due to planned maintenance or to faults on the network);
- the thermal capacity, often matching the standard transformer capacity installed across the network;
- voltage profile, ensuring it stays within the required limits, across the network, when operating both normally and abnormally; and
- the changing of the network design standards over time.

When network assets are replaced, either for condition or load reasons, a DNO will normally install the minimum cost scheme to ensure assets are not over invested. This approach can minimise the occurrence of stranded or underused assets; however, with subsequent near-future connection applications, it can also result in new construction projects to re-work and enhance equipment or circuits that have recently been installed. Such fine granularity of construction projects is rarely as cost-effective, safe, or customer service-oriented as judicious increase of the original building specification to provide a measure of ‘future-proofing’.

In East Lincolnshire, the OHL conductor size is one of the key network limitations. The design of the network has evolved over many years with different size conductors being installed. These tended to be a mixture of 0.1 inch² and 150mm² conductors up to the 1960’s, with the smaller conductor being installed in the most rural areas. From the 1970’s the majority of the conductors installed was 150mm² Aluminium Conductor Steel Reinforced (ACSR), with 300mm² Hard Drawn Aluminium (HDA) being installed in some on some of the trunk circuits supplying the larger population densities.

| | 0.1 Inch ² | 150 mm ² | 300 mm ² |
|----------------------|-----------------------|---------------------|---------------------|
| 1930’s-1960’s | 242.5km built | 211km built | – |
| 1970’s-2000’s | – | 187.6km built | 88.52km built |

Table 2 – OHL construction since 1930’s

Low Carbon Hub – Network Enhancements Work Carried Out

One of the LCH techniques was to ascertain whether additional functionality should be either designed or built into networks to make them more suitable for future generation connection. The DR5 OHL replacement programme for both load and condition reasons were routinely evaluated to ascertain if the most suitable asset for the future was being proposed. Sections of 33kV OHLs were being replaced between Alford to Trusthorpe and between Chapel St Leonards to Trusthorpe. They were identified as key circuits which, if the impedance was reduced, would unlock additional generation capacity for both conventional and alternative connections. In East Lincolnshire, nodal analysis modelling showed that even with the connection of relatively small new distributed generation connections near Trusthorpe, the relatively high existing network impedance and existing generation connections resulted in the network operating above upper statutory limit of 35,000V during periods of minimum demand.

At the time the OHL replacement was being planned, there were no generation applications that would benefit from a larger conductor being installed, however, the circuits being replaced in the LCH area were designed to have 300mm² HDA installed. The equivalent span length was 145m on H poles, taking two wooded poles with a cross bracing into account the provision for optical fibre both at the construction phase and as a retrofit activity. This conductor was double the cross sectional area and half the network resistance. 10.2km of 33kV network was rebuilt with 300HDA with the LCH design standard. Figure 13 shows a 300HDA line with SkyWrap applied.



Figure 13 – Fibre wrapped OHL (middle conductor)

The design of the larger conductor rebuilds under the LCH project were studied to understand the impact on the network under both intact and plausible non-intact scenarios, to ascertain what impact it has on the resultant power flows. This included varying the levels of generation at different points on the network to ensure the larger conductor did not cause unbalanced power flows that could limit the future capacity of the network system.

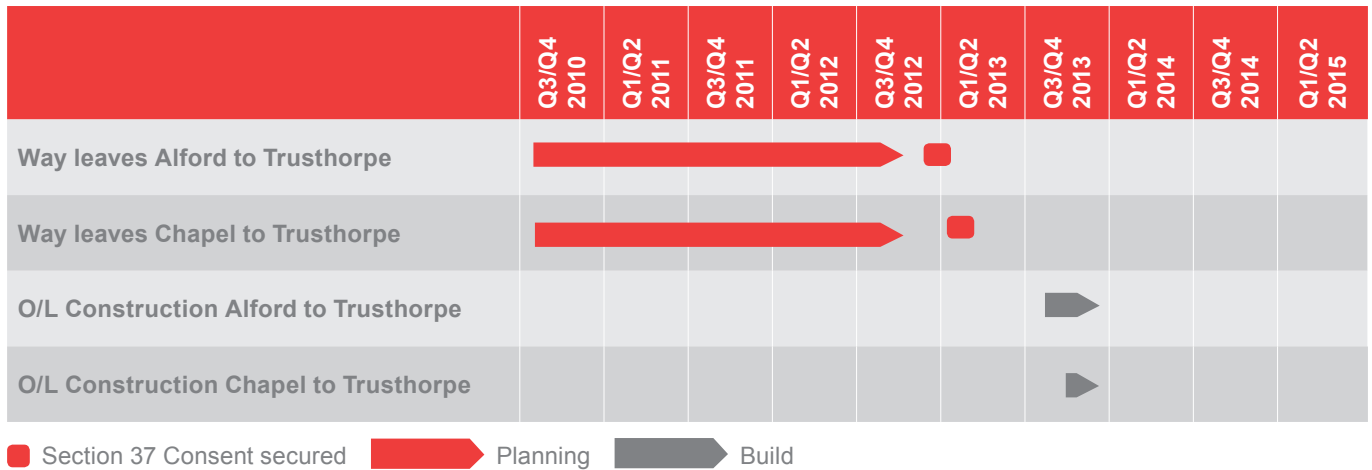

Figure 14 – Network Enhancements Project Plan

The two OHL rebuilds received all the required wayleaves from landowners in February 2013. Local Authority permission, Flood Defence Consent from the Environment Agency, Land Drainage Consent from Lindsey Marsh Drainage Board and DECC Section 37 consent were all received by August 2013, taking approximately six months to secure.

The rebuilding of the OHLs was carried out in sections, between Q3 2013 and Q1 2014. After each section was completed, the optical fibre team followed behind to wrap the new line. This increased the duration and cost of the wrapping contract but reduced the disturbance to landowners.

3.4 – Dynamic Line Ratings Overview

The increase of network capacity above rated capacity through real-time monitoring of equipment temperatures.

Background

Within the UK, Overhead conductors have specific static probabilistic current ratings based on seasonal weather patterns dictated by ENA Engineering Recommendations P27. These assume certain conservative static environmental factors such as wind speed, direction, temperature and solar irradiance absorption. The P27 ratings determine the maximum current rating to maintain the conductor below the maximum design temperature. With increasing current flowing through an OHL, the temperature of the conductor increases, which can either damage the OHL and/or cause the conductor to expand reducing the proximity to the ground.

OHL static ratings assume certain conservative static environmental factors such as:

- Ambient air temperature (°C)
- Wind speed (m/s)
- Wind direction (°)
- Incident solar radiation (W/m²)

The Skegness RPZ delivered innovative connections to offshore wind farms based on dynamic ratings of OHLs. This and other previous innovation projects have shown that OHL ratings are substantially increased during cold, windy conditions where the wind direction is perpendicular to the Line and have shown how the installation of multiple fixed weather stations could be used to accurately measure wind speed, wind direction and temperature accurately at several locations to achieve significant increases in an OHLs capacity based on real time weather data.

These benefits have been further developed by the LCH project, with the introduction of a low cost dynamic line rating solution, applied to selected 33kV circuits, which calculates whether the operating limits on these circuits can be enhanced based, this time, on real time asset data.

Low Carbon Hub – Dynamic Line Ratings Work Carried Out

Figure 15 shows the project plan for the delivery of the Dynamic Line Ratings method.

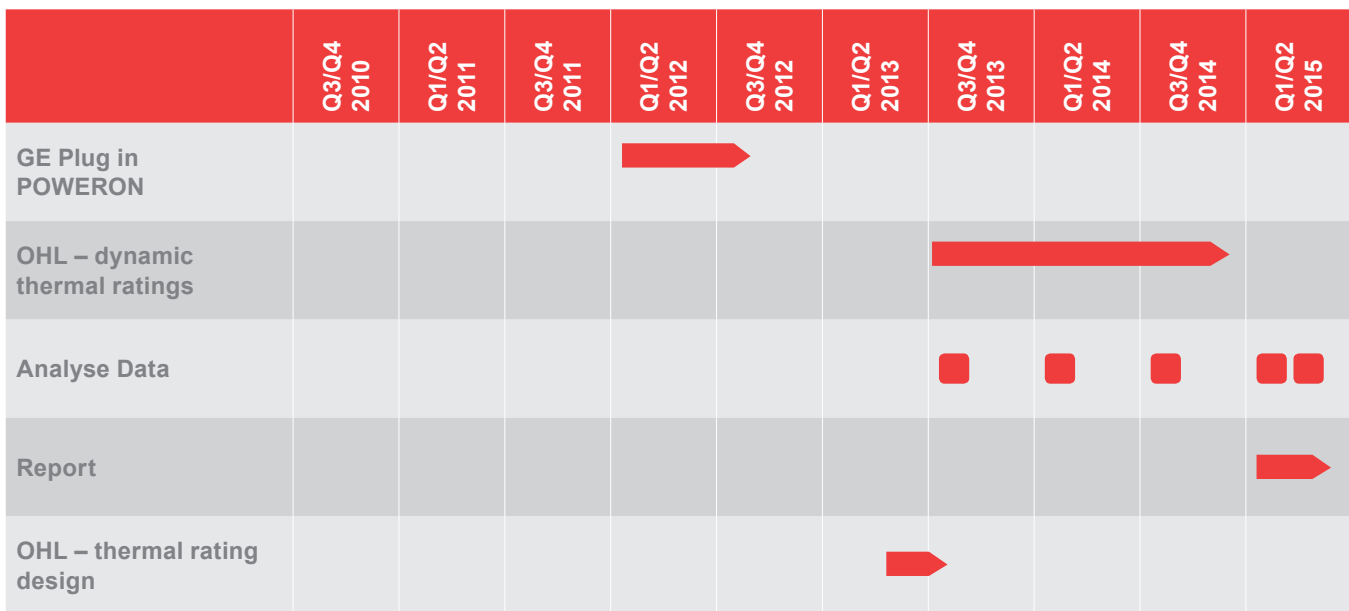

■ Analysis ➔ Delivery

Figure 15 – Dynamic System Ratings Project Plan

The LCH method of dynamically rating selected 33kV OHLs uses wind turbine electrical power output data from WPD’s NMS as the input for an OHL rating calculation.

The method converts the Electrical Output from multiple turbines into the wind speed at nacelle height using turbine manufacturer’s data, then calculates the wind speed at the OHL height using the wind shear power law, and finally incorporates the wind speed data into the Dynamic Line Rating algorithm with fixed pessimistic ambient air temperature, direction and solar radiation data to calculate a conservative maximum circuit rating. This makes best use of all the available information in a more cost-effective way than establishing dedicated weather stations.

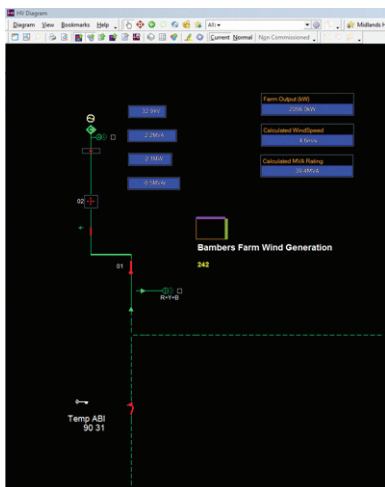

Figure 16 – Dynamic Line Rating PowerOn Screen shot

An example of the block diagram algorithm is included in Appendix H; the pseudo code was written by WPD in shell script within WPD’s NMS, PowerOn. Figure 16 shows the graphical conversion between electrical output and wind speed and the calculated capacity of an overhead circuit based on enhanced ratings. A polynomial plot for each windfarm was first created based on the installed generators, then simplified to a conservative linear trend to simplify calculations.

In East Lincolnshire, the selected 33kV OHLs can typically be dynamically rated up to 113% of the static winter rating. The results from the DLR were calibrated against an installed weather station at Skegness used for the 132kV DLR scheme. As is the case with conventional DLR schemes when there is a significant variation in terrain, the effectiveness of the measurement diminishes at a greater rate and would require additional measurement points.

3.5 – Dynamic Voltage Control

Overview

The increase in network capacity through the centralised control of the network voltage profile.

Background

The 33kV and 11kV network voltage profiles are controlled by AVC relays with fixed target voltages. These target voltages are derived for each network by analysing the worst case credible network scenarios, i.e. configuring the network for maximum voltage drop across the OHLs, cables and transformers with no contribution from intermittent embedded generation.

This technique was designed to build upon the principles demonstrated through one of our previous Innovation Funding Incentive (IFI) projects, where the target voltage on the network was actively varied based on both the demand and generation parameters measured locally at the grid substation. The LCH methodology involved using the real time measurements of demand and generation from across key remote network positions, to enhance the target voltage decision making process. This technique of enhancement will be described throughout the rest of the project as Dynamic Voltage Control (DVC).

Dynamic Voltage Control could either analyse additional information locally at the grid substation or centrally within the NMS. Both have advantages and disadvantages – see Appendix I. As part of the LCH design, both methods were evaluated with the centralised control option being selected.

Low Carbon Hub – Dynamic Voltage Control work carried out

Fundamentals Ltd supported the development of the DVC method due to their detailed knowledge of Voltage Control relays, power system analysis and their involvement with the previous innovation project. Figure 17 shows the project plan for the delivery of the Dynamic Voltage Control method.

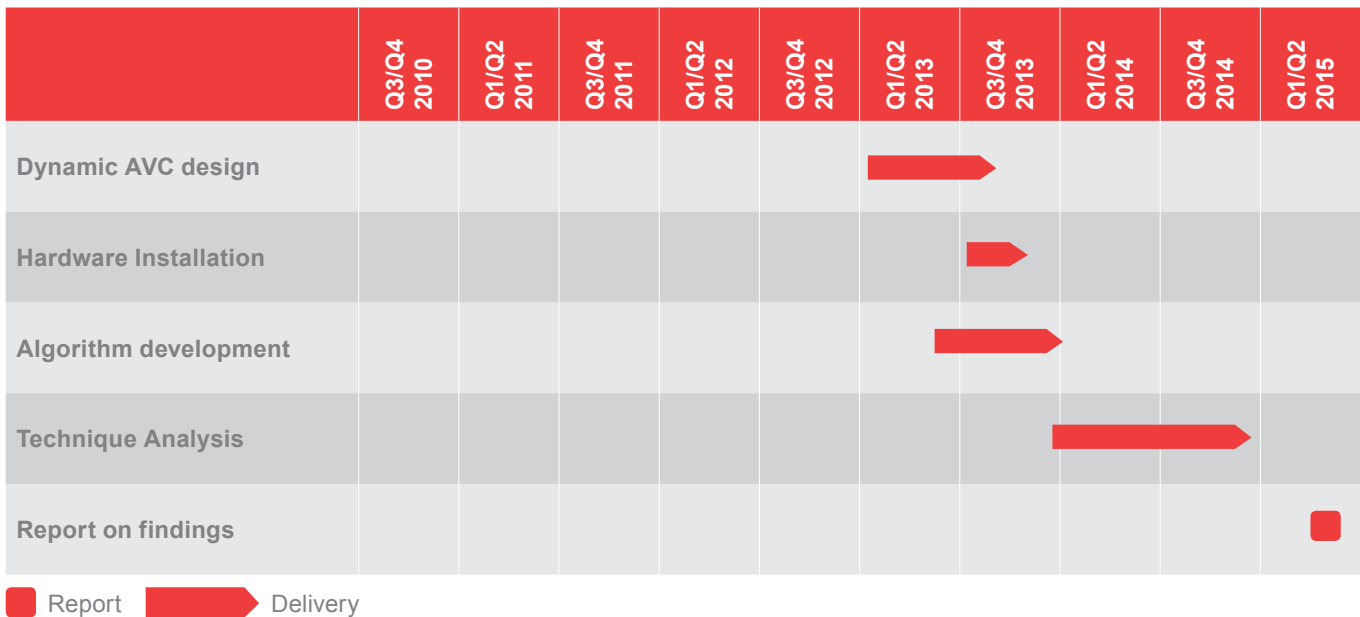

Figure 17 – Dynamic Voltage Control Project Plan

The Dynamic Voltage Control work comprises the following co-operating modules:

- Calculating voltages at key locations,
- AVC Hardware modifications to apply new voltage targets,
- Creation of an Algorithm and integration into WPD’s NMS.

These are next discussed in turn.

3.5.1 – Calculating voltages at key locations

The Horncastle Primary substation voltage is required for the Dynamic Voltage Control project; however there isn’t a 33kV measurement VT there. A suitable signal was thus derived using the output from the 11kV VT and various parameters of the main transformer measured through a new SuperTAPP n+ relay and collected remotely over GPRS. The actual calculation of the primary voltage value is called the Virtual Voltage Transformer (VVT), and the algorithm is hosted within the Nortech iHost server system. Further details of the equipment and algorithm have been included in Appendix J.

3.5.2 – AVC Hardware modifications to apply new voltage targets

As part of the LCH, the ability to amend the target voltage on both the existing hardwired control schemes and by controlling the AVC relay using DNP3 protocol was developed and tested. The additional AVC functionality required for the project to amend the target voltage had to be designed and achieved whilst maintaining all existing control functionality for both control engineers and field staff.

Due to the significant control changes, the relays were bench tested with hardwired controls and with DNP3 control through a D400 RTU for several months to demonstrate how the Dynamic Voltage Control operated with the DVC Algorithm in the NMS and with new RTU.

| Hardwired | DNP3 |
|--|--|
| Additional AVC functionality can be achieved using Hardwired controls through an Alternative Settings interposing relay and control through a GE D20 RTU. This allows the target voltage to be remotely amended. | Additional AVC functionality can be achieved using DNP3 communications; the target voltage can be remotely set through a GE D400 RTU. This allows a large range of target voltages to be remotely set. |

Skegness has a dual redundant AVC scheme installed for transformer, a SuperTAPP RVM v5 and SuperTAPP n+ as a legacy of a previous innovation project. Due to the more complex AVC arrangement, the decision was taken to retain the hardwired functionality for the duration of the trial until the legacy RVM relay is decommissioned and removed as part of another project. At this time, the SuperTAPP n+ will be transferred across to DNP3 control using the D400 RTU. The communications for DVC were through WPD's SCADA network.

3.5.3 – Creating an algorithm and integration into software

Fundamentals Ltd created the DVC algorithm for both hardwired and DNP3 control. The hardwired version was written in shell script within WPD's NMS. The algorithm analyses the network running arrangements by monitoring circuit breaker states and non-tele controlled isolators. It deduces the states of the latter from the latest configuration of the network, and thus ascertains which measurement points should be included within the voltage optimisation analysis. If the Algorithm can detect if the network is operating abnormally, the voltage measurement points will not be used in the algorithm calculations.

The key voltage and current measurements are fed into the algorithm, which first assesses whether the measurements are within credible limits. The algorithm next assesses whether the default target voltage based on the worst case credible network scenarios should be applied or whether a more optimal target voltage can be applied. The algorithm has a number of configurable factors and parameters to influence the algorithm operation & decision; At present the method has been configured for steady state operation, re-optimising less than 4 times per day.

When appropriate, the algorithm communicates to the AVC relays over SCADA to amend the target voltage. The algorithm logic has been included in Appendix K, this is the alternative settings version implemented as part of the Lincolnshire Low Carbon Hub.

3.6 Flexible AC Transmission Systems (FACTS)

Overview

The increase of network capacity through the precise and immediate control of steady state voltage and reduction of step voltage changes.

Introduction to the Problem

As detailed above, both the 11kV and 33kV networks have been designed with voltage regulation at the grid and primary substations. The network impedance and connection of demand and generation were all managed to ensure that the voltage profiles across all feeders remained within statutory limits.

Maintaining the voltage profiles within the statutory limits becomes more of an issue when network feeders have relatively high impedance and are trying to support connected generation or large demands. In these circumstances the use of FACTS devices is being demonstrated as an alternative to traditional network reinforcement since it can address the issues of both steady state voltage profiles and step changes in voltage.

Shunt Compensation – Work Carried Out

Large shunt compensation devices have primarily been installed for power factor correction, alongside non-synchronous Distributed Generation and on transmission networks for voltage stability and reactive power management. Within the UK only a handful of SVC or Statcom devices have been installed for DNO use, primarily on island networks to mitigate step change issues.

The LCH, project required shunt compensation to be procured and installed in parallel with the electricity network at one of the weakest points of the network to operate as a controllable current source. A Distribution Static Compensator (DStatcom) device was selected above a Static Var Compensator. This is because a Static Var Compensator's (SVC) reactive power output is linked to the network voltage whilst a DStatcom is independent of voltage and provides a better transient performance. The DStatcom allows reactive power to be generated or absorbed by altering its effective capacitance or inductance values and is thus a practical means of controlling power factor or voltage. The solution was procured and designed in such a way as to maximise the amount of generation that can be connected. Figure 18 show the project plan for the delivery of the FACTS method.

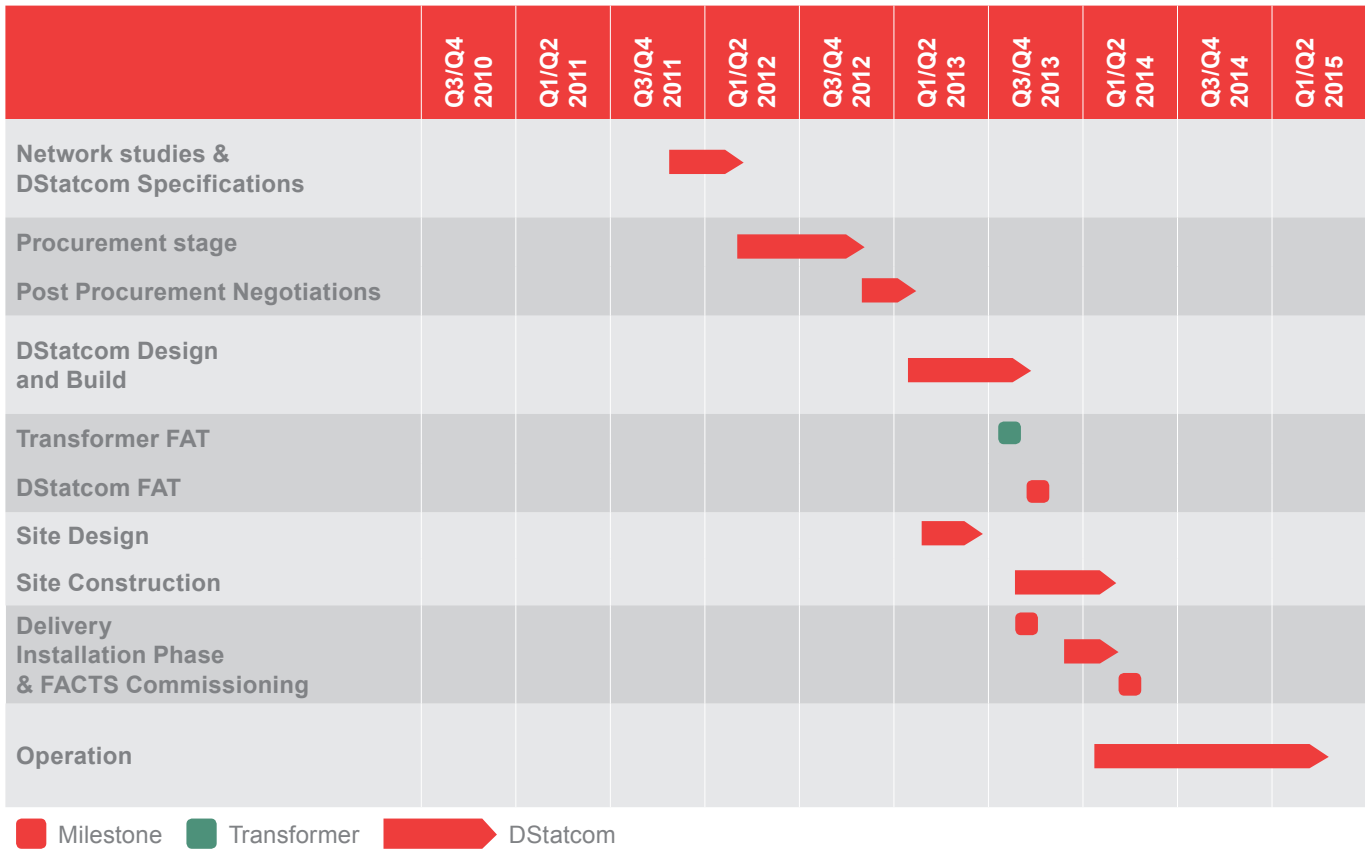

Figure 18 – DStatcom Project Plan

Pre Procurement & System Studies

Before starting a competitive procurement process, an equipment specification policy was written (EE SPEC:200) and a series of internal and external studies were completed. This ensured the procured DStatcom would be fit for purpose and could be effectively integrated into the distribution network. Further details can be found in Appendix L and M, Knowledge dissemination report and The DStatcom full technical report.

We issued an ITT (Invitation to Tender) for a Shunt connected device required to meet the functional specification EE/200 – 36kV Static Synchronous Compensator for the Lincolnshire LCH. The tender received 4 responses, an S&C 3.75MVar DStatcom was procured.

The DStatcom was connected in parallel with the electricity network at Trusthorpe to operate as a controllable current source (an arrangement often referred to as ‘shunt compensation’).

The installation of the DStatcom was carried out in conjunction with the replacement of the primary transformers at Trusthorpe. As shown in Figure 20, the DStatcom has been installed between two bus sections with a transformer breaker protected using an overcurrent and earth fault relay. This allows the DStatcom to be operated whilst connected to either radial feeders or whilst the network is operating as a ring.

The civil works were carried out by Western Power Distribution. The installation of the flood frame, DStatcom container and DStatcom Transformer was completed by S&C Electric. Figure 20 shows the DStatcom installed in its own enclosure within Trusthorpe primary substation. The full technical report on the DStatcom is included in Appendix M.



Figure 20 – DStatcom at Trusthorpe primary substation – Photo

Policies, Standards & Training

In addition to the equipment specification used during the procurement phase, four further policies have been written so the DStatcom can be safely and effectively integrated into the distribution system to regulate the network voltage.

1. Policy overview of DStatcom Equipment at Trusthorpe Primary substation,
2. Operational Safety considerations when working on or around the DStatcom Equipment at Trusthorpe Primary Substation,
3. Maintaining and Working on DStatcom Equipment at Trusthorpe Primary Substation,
4. Operation and Control of DStatcom Equipment at Trusthorpe Primary Substation.

These policies have been distributed to all WPD employees, and specialist training sessions have been run for Network Control Engineers, engineering specialists and operational staff working in East Lincolnshire.

Control System Integration

The DStatcom's control system has been fully integrated into WPD's PowerON software. Through the D20 RTU installed on site the following controls, analogues, indications and alarms are visible within PowerON. Full details of the DStatcom's integration are detailed in the FACTs technical report.

The primary method of starting, stopping and amending DStatcom settings is through PowerON. In the event of a loss of communications with PowerON, the DStatcom is fully automatic and will continue to regulate the voltage using local measurements points. The protection panel within Trusthorpe 33kV switchroom contains a local enable / disable functionality.

The local Human-Machine Interface (HMI) within the DStatcom has been configured for the reporting of performance, (it records 10 second snapshots) alarms, and alarm resets. The DStatcom has no connection to the internet and cannot be remotely controlled except through PowerON.

3.7 – Telecommunications

Overview

The telecommunication support for the six LCH measures as already described above.

Background

The requirement for advanced telecoms was identified as an enabler for a number of the LCH techniques, such as part of Dynamic Line ratings, the current differential protection traffic for the Ring Network and the backhaul of data for the Advanced Voltage Control. Existing communications for SCADA traffic is Ultra High Frequency (UHF) radio; this has a relatively low latency and bandwidth. However, it is not suitable for the high speed and bandwidth data requirements for current differential protection traffic, and it could be a limitation for other methods where network data is required to support network operational decisions.

Low Carbon Hub – Telecoms Work Carried Out

A key requirement of the project was to investigate what would make a suitable telecommunications link between primary substations for both network protection and other data requirements. The protection requirements for the LCH and advanced network operation require a reliable, low latency communications medium for protection purposes.

We chose a combination of optical fibre and microwave communications to achieve this specification. We chose to trial both wired and wireless communications channels as part of the project to further reduce the impact of any one communication technology failure. A review of the available wired and wireless communications communication media was conducted and a report published on www.westernpowerinnovation.co.uk/documents.aspx. Figure 21 shows the LCH telecoms channel requirements and final design overview.

3.7.1 – Optical Fibre

Fitting optical fibre and microwave communication links for primary substation current differential protection schemes was a new area to WPD. As such there was a level of project risk, as with any new technology. Through the project we evaluated three main options for attaching fibre to wood pole OHLs:

- 1.** Optical Phase Conductor (OPPC): this requires the re stringing of the centre phase, and is thus a high cost installation for retrofits. This also requires sufficient spare conductor to be strategically stored for repairs. The use of OPPC could lead to extended periods of time when the optical fibre is not available for protection traffic. Therefore OPPC was not considered for the project or WPD's fibre standard.
- 2.** All-Dielectric Self Supporting cable (ADSS): Whilst a simple approach in principle, on the existing OHLs where fibre was required on in East Lincolnshire, the ADSS could not be installed without either reducing the ground clearance which would have caused issues with the very large farm machinery used locally. Other issues included causing an unacceptable risk of clashing or requiring height increases for a number of poles. Therefore, ADSS was not an appropriate choice for the surveyed east Lincolnshire lines.
- 3.** Optical Fibre Wrap (SkyWrap): This is applied to the centre phase of the existing OHL; the conductor provides the mechanical strength for supporting the fibre.

96 fibre SkyWrap was selected to provide communications on both new 300HDA circuits and existing 150 ACSR circuits between Skegness to Alford and Alford to Trusthorpe. Studies showed that one of the implications of the wrap was increased conductor sag under certain conditions; three existing spans would no longer meet WPD's OHL clearance policy, so at these locations the line height was increased.

A new standard technique for installing Fibre Optic cables on wood poles OH4U has been written to take into account the techniques developed in the LCH project and the lessons learnt.

3.7.2 – Microwave Links

The project installed three 15m microwave towers and three microwave links installed between Skegness to Ingoldmells, Ingoldmells to Chapel St Leonards and Chapel St Leonards to Trusthorpe.

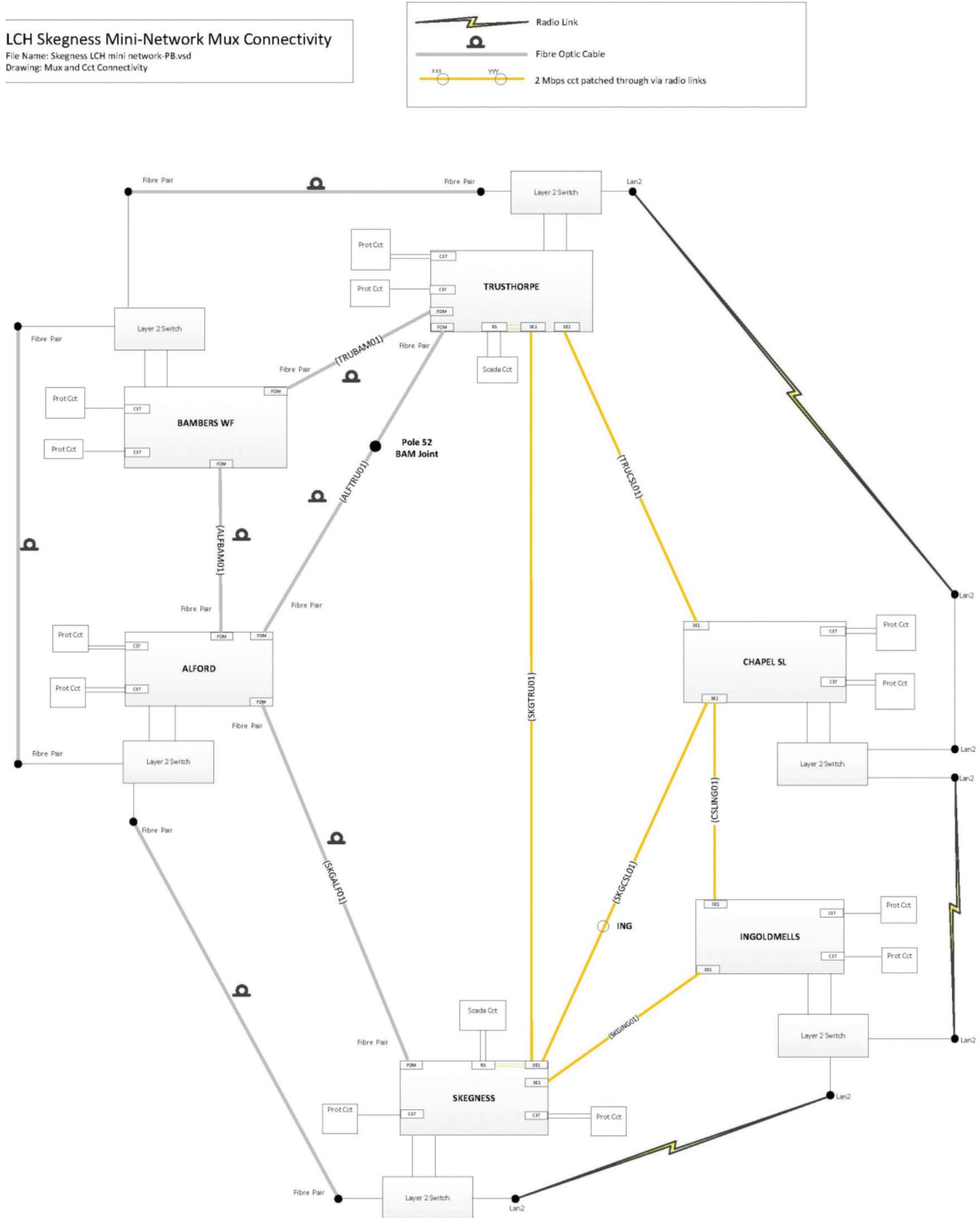

Figure 21 – Lincolnshire LCH Telecommunications installation

Section 4 Project outcomes

The outcomes and learning associated with the LCH project and each method was published as a stand-alone Knowledge Dissemination document, included in Appendix L. The outcomes for the individual methods have been summarised in this section.

4.1 – Commercial Agreements

Commercial Agreements have cost effectively unlocked additional Generation Connections within East Lincolnshire, allowing generation developers to access the spare capacity within the network which conventionally has thermal and voltage restrictions. At the start of this project Alternative Connections were estimated to be at Technology Readiness Level (TRL) 6³ whilst at the end of the project this had been estimated to have risen to TRL 8-9.

4.1.1 – Alternative Connections

There has been and remains a strong appetite for Alternative Connections, with a large number of Generation Developers requesting and accepted by offers in East Lincolnshire as a way of unlocking capacity in areas otherwise considered constrained. Customers also expressed an interest in other geographical locations which often trigger prohibitive connection costs.

The following new definitions and terms have been adopted by WPD for use in the Alternative Connections. The descriptions are included in the Commercial Arrangements report in Appendix B.

| New definitions | Key new terms |
|--|---|
| <ul style="list-style-type: none"> Alternative Connection | <ul style="list-style-type: none"> Adjusted Export Capacity Protected Export and Import Capacity Curtail/Curtailment means |

The use of Alternative Connections documents was approved and we began issuing them to customers in February 2014. This allows for the DG Export capacity to be amended through the automated Active Network Management system installed in East Lincolnshire. As of February 2015, a total of 34 Alternative Connections offers have been offered in East Lincolnshire and Alternative Connections have facilitated the additional 48.75MVA of additional generation connections as detailed in Table 3. The level of risks some DG developers appeared to accept was higher than DNOs forecasted. Feedback indicated that this was due to some DG developers made their own assessments of assumptions and risks when studying Alternative Connections.

| Type | Number of application | Number of application (MW) | Number of acceptances | Number of acceptances (MW) |
|---------------------|-----------------------|----------------------------|-----------------------|----------------------------|
| Wind | 9 | 47.05 | 3 | 29.95 |
| Solar | 17 | 104.62 | 2 | 18.8 |
| Anaerobic Digestion | 8 | 19.22 | 0 | 0 |

Table 3 – Breakdown of connections offered and accepted

At the trialling stage, Alternative Connection offers substantially increased the connections workload as the studies required are more comprehensive and many aspects of the offer letters cannot be automated.

Alternative Connections are not the right choice for all new generation developers. In the same way that developers evaluate the increased costs of a firm connection over the risk and consequence of constraints with a non-firm connection when the network is operating abnormally, with an alternative connection a generation developers must also evaluate the capital cost savings from an Alternative Connection over the potential longer term reduction in revenue from an Alternative Connection.

4.1.2 – Active Network Management

Active Network Management has been installed by WPD, has been operational since April 2014, and is ready for our accepted Alternative Connections DG customers when they have received all of their necessary permissions to proceed to construction and site energisation. The ANM scheme prevents the potential voltage and thermal exceedances that could occur under certain scenarios.

³ Technology Readiness Level is a measure used to assess the maturity of evolving technologies. It is graded on a scale from 1 to 9

One of the key requirements to the success of an ANM system is the setting of suitable Trim, Trip, Sequential Trip and Global Trip limits for each measurement point, imposed to constrain and release generation within the ANM scheme. This is required to ensure all sections of the network remain within their design and statutory parameters. If these settings are too low, DG sites will be constrained off prematurely and the capacity within the network will not all be released. If the settings are too high, the generation could lead to cascade trips and global trips. Artificial constraints need to be considered to compensate for the n-1 scenarios, e.g. what are the resultant voltage profiles and power flows when a circuit or transformer trips. The network limits and the protection settings needed to be carefully studied to avoid further cascade trips. Otherwise, installing Active Network Management can reduce the actual conventional capacity within a network before a generator needs to be constrained, this takes into account the tolerance required for ramp down time and communications latency, ensuring that network limits are not breached. The settings were derived after detailed studies of network demands, existing generation and new generation outputs, rates of change, sensitivities and protection settings.

4.1.3 – Constraint analysis software tools

The LCH Constraints Analysis tool successfully showed the software can be designed and packaged for a DNO to conduct constraints analysis studies themselves, producing repeatable results. The desktop constraint analysis tool has been used by the Future Networks Team and Primary System Design engineers to model and understand how a new generation connection would have been constrained historically, to identify the optimal point of new connections, the resultant power flows and the potential reinforcement (conventional or innovation) required to reduce a constraint.

It is not possible for a DNO to provide an estimation of future constraints or guarantee network availability based on LIFO as there are a number of factors that are outside of a DNO's control which could either increase or decrease the constraints a generator may experience. Instead, we have advised customers of the likely constraints based on historical network operation and run a number of scenarios using this data. There is a requirement to make generation developers aware of the factors that can potentially increase or decrease future constraints. Generation developers should also be encouraged carry out their own due diligence studies to better understand the risks; it also requires the DNO to be very clear about the assumptions made when undertaking any constraint analysis.

4.2 – Ring Method

This arrangement also increases power flow route diversity, with the associated benefits to system availability and losses reduction.

The project showed that an existing radial network could be modified, rather than rebuilt, to enhance capacity. It is now understood that the use of 33kV switchboards at a number of sites would have been an economically advantageous alternative to an Air Insulated Switchgear (AIS) or hybrid AIS solution since it offers a reduced network risk during an offline build, a quicker construction phase, and a simpler network to operate.

The learning from the project also showed that, having suitable current and voltage transformers in the right locations is often a limitation to smarter solutions which often require a greater number of measurement points. Both the ring network and the DVC method has shown how additional CTs can be incorporated into existing networks (Alford, Chapel St Leonards and Ingoldmells), how additional VTs are best incorporated into AIS sites (Alford & Ingoldmells), how additional VTs are best incorporated into GIS sites (Trusthorpe) and how additional VTs are best incorporated into hybrid AIS/GIS sites (Chapel St Leonards).

In both operational compounds and switch rooms space is at a premium, so careful consideration is required regarding safety, maintenance, and future works, as well as accommodation of the new equipment. All designs were vetted to ensuring that primary substations were not sterilised by the work being completed under this project.

Meshed networks can cause particular protection issues with very rural networks and the associated low fault levels. With high levels of inverter driven generation, differentiating between a network fault and high steady state output from the connected generation very difficult. A two and three ended current differential scheme with distance backup was selected as the best way method of protecting the network.

The Current Differential schemes have shown themselves to be effective protection scheme for this network. Several links have required detailed investigation and amendments of settings due to a number of current imbalance alarms occurring, especially during low periods of demand.

The decision to include Ingoldmells substation and the associated OHLs required a number of complex decisions to be made. The inclusion of Ingoldmells significantly increased the number permutations and complexity for both normal and abnormal running arrangements leading to delays in selecting an acceptable LCH design that can be adequately protected. The learning from this method is that a number of robust mitigation plans should be in place to account for changes in the design as the method progresses.

4.3 – Network Enhancements

Reconductoring a circuit with a larger conductor reduces the resistance of the circuit whilst the reactance remains virtually unchanged. For the LCH, the replacement conductor reduces the voltage drop when the network is demand driven, reduces the effects of voltage rise when the network is generation driven and reduces the network losses – all good features. The Network Enhancements have increased the summer capacity of the circuits from 16MVA to 41MVA and it has been modelled to reduce voltage rise by 24% compared to the existing circuit during maximum reverse power flows.

The fibre wrap marginally impacts the Max Conductor Tension (MCT), Max Conductor Weight (MCW) and Max Conductor Pressure (MCP). At maximum span length of 190m, maximum design temperature the sag increases from 7.02m to 7.29m. This was taken into account during line re-profiling to ensure clearances were still maintained. At the same time, the maximum clashing span was reduced from 190m to 178m. WPD's OHL design software correctly models conductor sag based on tension. Adding fibre wrap to an existing OHL increases the weight rather than the tension. As conservative settings have been applied using conservative, ensuring statutory clearances are maintained.

At the start of this project Network Enhancements were estimated to be at TRL 8. At the end of the project the TRL has been estimated to be TRL 9.

4.4 – Dynamic Line Ratings

The method has showed that using wind farm electrical data can cost effectively calculate an enhanced theoretical rating of the OHL based on using the calculated wind speed data. The method could be used most where clusters of wind farms occur close to the grid substation or when a network is being run abnormally. The technique can supplement either Met Office data or weather stations to calculate the dynamic ratings of a line.

A circuit's rating will include the OHL, cable sections, current transformers (CTs), and circuit breakers (CB). Whilst an OHL can be dynamically rated, assets such as CTs and CBs have fixed asset ratings. These fixed ratings can prevent the full dynamic asset ratings of the OHL from being reached. In East Lincolnshire, the 33kV OHLs can typically be dynamically rated up to 113% of the static rating before the OHL is no longer the limiting component. Operating the circuit above these fixed ratings can result in premature aging and asset failure.

Any dynamic or enhanced Line rating algorithm must take into account any section of the OHL where the environmental conditions differ from the measurement locations. This must also include if a section of an OHL is sheltered and how a circuit could become sheltered whilst being dynamically rated. Sheltering can occur due to natural reasons such as tree growth or if manmade structures are located within close proximity of the line. A survey of the overhead feeders being dynamically rated in the LCH project identified a new industrial building which had recently been erected within close proximity of the OHL since the last statutory line patrol; the OHL was diverted due to fully comply with horizontal statutory clearance requirements, however this highlighted the risks of an OHL becoming sheltered at any point after DLR has been applied.

The project has also shown that where the fixed asset ratings are not the limiting factor and sheltering is not an issue, wind farm data could be used in conjunction with weather stations and/or Met Office data to make the use of dynamic line ratings technique more flexible, reliable and mitigate any potential failure of weather stations.

The existing limitation for additional generation connections across the East Lincolnshire network was due to voltage rise, meaning the circuits did not operate beyond the static ratings and into the enhanced ratings during the project. The existing installed weather stations were used to sense check and validate the enhanced ratings.

4.5 – Dynamic Voltage Control

This technique has shown there are substantial opportunities to optimise target voltage settings by using an algorithm to review the voltage profiles and power flows across the network. The technique has the highest value in locations where there is a significant difference between maximum and minimum demands, there are different demand profiles across the network, or when the feeders are of a similar length or have similar voltage profiles but large levels of intermittent generation are connected.

VVT is a lower cost, quicker and simpler solution to installing new VTs and associated equipment into an existing primary substation for steady state measurements; VVT is suitable for steady state measurement but not for protection purposes. The cost of retrofitting VVT into an existing standard SuperTAPP® n+ scheme has been estimated at £4k, whilst the associated cost of installing a fixed outdoor VT is approximately £40k, although this is site dependent. (This latter price includes the purchase and installation of the 33kV VT, structure, plinth and multicores back to the RTU.)

The algorithm received significant testing in an offline server, using live network information, to simulated decisions the algorithm would take. This further de risked the operation of the network until the algorithm could be shown to be predictable and stable. The DVC algorithm is configured and has been programmed to target no more than four voltage changes per day. This will allow the voltage profile to optimise for long term steady state power flows rather than short term transients in load or generation.

There is a requirement to understand whether voltage measurement points are being influenced by the AVC being optimised because, if the DVC system is not aware when the network is operating abnormally, there is a possibility that under abnormal network configurations the voltage optimisation takes into account unrelated information and incorrectly calculates the target voltage settings. The DVC has been designed to maintain statutory limits after credible n-1 scenarios, taking into account and calculating the voltage profiles after a fault, when calculating and re-optimising the voltage profile.

The DVC algorithm has been configured to revert back to the normal settings in the event the network is working abnormally or a parameter is outside of its pre-defined range. If the communications fail whilst in the alternative settings, the relay will remain in that setting until the communications are reset or the relays are manually changed to normal settings or manual control. The alternative settings value has taken this into account for the project.

This method has been designed to operate independently of the ANM scheme installed at Skegness; without the ANM scheme, the current DVC could not be used to unlock capacity due to the current associated risk of communications failure or the effect of abnormal network operation. If the DVC is operating with an optimal voltage target, the voltage headroom across the network will be increased, reducing the likelihood of generation being constrained for voltage issues. If the DVC is not operational, or cannot optimise the voltage profile due to abnormal operation, or the voltage profiles across the network do not allow the voltage target to be amended, should any voltage violations be seen, the ANM scheme will constrain generation to reduce the effect on the network. DVC could be incorporated into Active Network Management scheme areas.

The method has shown there are opportunities to further optimise voltage profiles across the primary network using additional network information. The learning has shown that the technique needs to be more robust in order to unlock additional generation capacity outside of an ANM area. When a robust method of Dynamic Voltage Control has been demonstrated and applied in appropriate areas, the Cost Benefit Analysis will be high, by increasing generation connections for both conventional and alternative connections.

4.6 – Flexible AC Transmission Systems

The OHLs supplying Trusthorpe primary substation from Skegness grid substation are 26.2km and 26.3km long. The line impedance, and location of embedded generation, means Trusthorpe sees a very wide voltage range and so is an optimal location for the DStatcom.

- When the DStatcom is operating at 100% capacitive mode (exporting reactive power) the voltage at the POCC is boosted by 3%.
- When the DStatcom is operating at 100% reactive mode (importing reactive power) the voltage at the POCC is reduced by 5%.
- The DStatcom can operate at 263% of the nominal output (3.75MVA_r) for two seconds in the event of a network disturbance.

The WPD DStatcom complies the noise policies, however unless additional noise mitigations are put in place – the audible noise generated by the DStatcom installed in Trusthorpe is likely to limit their use in substations in close proximity to customers. The additional noise generated by the DStatcom is both around the 150Hz, generated by fan the cooling fans, and at the 5kHz generated by the power electronics. The higher frequency noise is very noticeable close to the device but attenuates before the boundary of the substation. The 150Hz noise generated by the cooling fans will be the limiting the installation of these devices within close proximity of customers. Further information can be found in Appendix M (FACTs Report).

4.7 – Telecommunications

There was originally concern that the Optical fibre wrap would have a negative impact on the aesthetics of the OHL. However, we found that the effects of wrapping the OHL are not significant and would not prevent us from wrapping further OHLs. Careful consideration at the design stage is required for the location of earthing of splicing canisters. Failure to do so can result in reduced operational functionality.

All 96 SkyWrap fibres passed the testing to WPD's standards, and have continued to operate satisfactorily since. Microwave links were required between Trusthorpe, Chapel St Leonards, Ingoldmells and Skegness primary substations. Whilst desktop studies showed that towers at 15 meters would allow a clear line of sight between all substations, the line of sight tests indicated otherwise. However, satisfactory alternative locations within the substation boundaries were found. One of the three microwave links has been subject to higher than expected loss of communications, both long term and short term dropouts. This is particularly evident during gusty periods. This continues to be investigated by WPD's SURF team.

Permitted development rights were used to secure the installation of new towers at Trusthorpe, Chapel St Leonards and Ingoldmells primary substations. 15m is the maximum height for permitted development. Taller towers require planning permission, however, we had identified a number of mitigation plans in the event that permission for the necessary microwave towers and links was refused.

Section 5 – Performance compared to the original project aims, objectives and success criteria

5.1 – Project Aims

Project Aim 1)

Creating an active smarter design and operation of the network will allow generation to be connected to the distribution network more economically. This will allow the most suitable generation sites to connect to the network. ✓

The Lincolnshire LCH six project methods have demonstrated how smarter design and operational principles can be used and have unlocked additional generation connections, see Section 3. As a direct consequence of the project an additional 48MVA of generation connections have already accepted Alternative Connections. These would not have been possible without the project's new technologies, operating procedures and commercial arrangements.

Project Aim 2)

The LCH solution will develop a distribution network optimised for demand and generation whilst demonstrating solutions to some of the network limitations. ✓

This has been achieved through:

- Alternative Commercial Arrangements – See Section 3.1 for more details.
- Dynamic Voltage Control – See Section 3.5 for more details.
- The DStatcom – See Section 3.6 for more details.
- The 33kV Active Ring and Network enhancements – See Sections 3.2 and 3.3 for more details.

Project Aim 3)

Accelerates the connection of renewable DG – Novel approaches will enable renewable DG to connect more quickly and at a lower cost than with conventional solutions. This zero carbon generation will reduce the carbon content of the local grid. Generation and demand will be balanced at a local level in real time, minimising the need for imports from the national grid, and occasionally allowing low carbon exports. ✓

The LCH techniques have been installed ahead of the generation. The Lincolnshire LCH achieved the ANM system being scoped, designed, installed and commissioned within 6 months. This ANM system has been carried out ahead of the Distributed Generation connection aspirations. The other LCH methods, such as the 33kV Active Ring, Dynamic Line Ratings, Dynamic Voltage Control and the FACTS device have been carried out quicker than most traditional network reinforcements and at a much lower cost. See Sections 3 and 4 for more details.

Project Aim 4)

Increased visibility and control of the 33kV system (e.g. power factor, voltage management and power flows) and reduces emitted carbon from technical network losses. ✓

The Lincolnshire LCH methods have resulted in additional transducers and communications being installed across the LCH area vastly increasing the visibility of voltages, real and reactive power flows. The Dynamic Voltage Control can both manage and optimise network voltage across the network. Network Enhancements have reduced network impedance. The DStatcom can be used to both manage voltage rise on the network at the remote ends and to balance to power factor across the network to reduce losses. See Section 3.3 3.5 and 3.6 for more details.

Project Aim 5)

Reduces the carbon footprint associated with construction activities – A single strategic investment as proposed will eliminate the need for multiple infrastructure projects. ✓

The Lincolnshire LCH carried out all the construction activities as part of a coordinated single programme of works. See Section 3 for more details. The methods such as Active Network management, Dynamic Voltage Control, FACTS device have shown how innovative techniques & operations can be used as an alternative to often more carbon intensive conventional network reinforcement.

Project Aim 6)

Demonstration of previously unproven high voltage network assets ✓

The LCH demonstrated DStatcom into the 33kV distribution network – see Section 3.6

The Network Enhancement – See Section 3.3.

Project Aim 7)

Real time management of connected DG and relationship with DG customers ✓

Active Network Management control scheme – See Section 3.1. The Alternative Connections agreements have been developed in conjunction with DG customers to ensure they are suitable for both parties. See Appendix B and Appendix N.

5.2 – Project Objectives

Host a workshop with generation developers interested in connecting to the LCH ✓

Several workshops were held with generation developers. An independent survey has been conducted by Accent to assess the current relationship between WPD and DG developers. The feedback on the LCH Project has been included in Appendix B.

Dissemination to the other GB DNO's and IDNOs of design recommendations for connecting optical fibre and wireless links to new and existing wood pole overhead power lines ✓

A desk top study was completed in May 2012 and includes a review of methods for applying optical fibre to 33kV overhead lines and wireless communications between distribution substation sites. The report makes recommendations for the project based on new build and existing assets and will be available externally on the WPD website. <http://www.westernpowerinnovation.co.uk/Document-library/2011/LLCH-Communications-Review-v1.aspx>

Dissemination of a new set of commercial agreements jointly created between generators and the DNO. ✓

See Appendix B for a copy of the Alternative Offer letter and Alternative Connection Agreement.

Completion and demonstration of the dynamic voltage control capability implemented within GE POWERON (Network control system widely used by UK DNOs) ✓

The installation of hardware at Horncastle was completed in June 2014; Skegness hardware was installed in December 2014. The voltage optimisation algorithm has been updated and transferred to the live system after sufficient testing.

| | |
|---|---|
| Completion and demonstration of the dynamic voltage control capability implemented within GE POWERON (Network control system widely used by UK DNOs) | ✓ |
| Dynamic Line ratings have been applied in the LCH area using telemetry data from an existing wind farm. Several key circuits whose capacities were previously limited by their OHL ratings are now displaying an enhanced rating in the Network Management System PowerOn. See Section 3.4 | |
| Completion of the nominated 10.5km of OHLs that have already been included in the DPCR5 submission to the new LCH standard. | ✓ |
| 10.2km of OHL has been rebuilt to the LCH standard – See Section 3.3 | |
| Installation and commissioning of the Flexible Alternating Current Transmission system (FACTS) device | ✓ |
| See Section 3.6 for details of the installation and commissioning of the FACTs device. | |
| Operation of the 33kV active network ring connecting Alford, Trusthorpe, Chapel St Leonards and Skegness. Creating a network suitable for demonstrating the high penetration of DG. | ✓ |
| See Sections 3.2 and 4.2 | |
| Completion of the LCH, demonstrating the knowledge from the six project areas. | ✓ |
| The LCH has been completed generating significant learning in all six project areas. This learning has been shared through six-monthly reports, Technical reports, dissemination events, conferences, workshops and 1 to 1 meetings with other DNOs. | |
| Dissemination of knowledge to other DNOs, IDNOs and distributed generators. | ✓ |
| Knowledge report produced and circulated to all DNOs and published on the WPD Innovation website http://www.westernpowerinnovation.co.uk/Document-library/2015/LLCH-Knowledge-SDRC-V1.aspx | |

The LCH Project has managed to achieve all of the successful delivery criteria tabled below, as stated in the direction issued by Ofgem on the 20/11/2013.

5.3 – Project Successful delivery reward criteria

| Successful delivery reward criterion (SDRC) | Proposed evidence | Actual evidence |
|---|--|---|
| Host a successful workshop with Distributed Generation developers and feed learnings into the project plan. | Holding an interactive workshop by the end of 02/2011, collating feedback from attendees during the workshop sessions. A satisfaction survey will be carried out within 30 days of the event to gauge the value of the workshop to participants and identify any further follow up actions. | As detailed in the June 2011 six monthly report, an interactive workshop was held, the feedback from the workshop survey is detailed in Appendix A. The project continued to engage with stakeholders and held a subsequent workshop with DG customers where we presented the proposed alternative connections. The Alternative proposals was presented and to the wider industry |
| Development of UK technical recommendations for: <ol style="list-style-type: none"> 1. Installing optical fibre on existing wood pole OHLs; 2. Installing optical fibre on new wood pole OHLs 3. Installing microwave or radio antennas and associated equipment within the proximity of distribution assets including the configuration of equipment for effective system protection. | A set of three comprehensive documents sent to all UK DNOs and IDNOs before 31/05/2011. These documents could form the basis of future ENA Engineering Recommendations. The technical recommendations will provide costs and designs for generic OHL construction. Western Power Distribution will also present lessons learnt from project management and engineering experiences associated with delivery of the three aspects. This will be carried out on a minimum of an annual basis. A final report will be included in the project closure documentation in 02/2015. | All three documents (existing wood pole OHLs; Installing optical fibre on new wood pole OHLs and Installing microwave or radio antennas in existing substations) has been shared with the industry. Designs and costs have been created through the construction of the telecoms network. Further details are included in Sections 3, 4, 6, 8, 9 and 10. Learning has been routinely shared as detailed in Section 12. WPD's OHL Policy Engineer will continue to raise technical recommendations at industry OHL engineers meetings. |
| Completion of the first application of dynamic system control and operation using GE POWERON. | Evidenced through the handover of the capability to the Network Control centre. In accordance with our normal IT business processes the handover will have a documented Operational Acceptance certificate approved by the project board during the 08/2012 meeting. | As detailed in the December 2012 six monthly report, the GE PowerOn dynamic system rating plugin was incorporated within WPD's NMS. The handover and acceptance followed WPD's standard IT process. Section 3.4 shows how the technique was conducted. |

| | | | |
|---|--|--|----------|
| <p>Determining the degree to which voltage can be controlled by installing and operating a FACTs device. In particular, ascertain whether the device improves quality of supply to demand customers and/or improves generator network availability.</p> | <p>Install a FACTs device, and connect to our network by 01/2014. We will operate the FACTs device under a variety of network conditions and demonstrate how generation could be used to support the system under abnormal operating conditions. The knowledge learnt from this element of the project will be disseminated through a technical paper. The dissemination will be supported by a site visit for interested parties to the FACTs device location. The paper and the visit will be completed by 07/2014. A final report will be included in the project closure documentation in 02/2015.</p> | <p>As detailed in the May 2014 six monthly report, the FACTs device was connected to the network in January 2014. The DStatcom has been operated both in fixed VAR mode and in Volt mode with a range of target voltages and slopes. All DNOs were invited to a dissemination event held in Louth, which included a site visit to Trusthorpe Primary substation. 5 of the 6 UK DNOs attended the event. All DNOs received a copy of the slides, the policies, standard techniques and technical paper.</p> | <p>✓</p> |
| <p>Development of a stronger relationship with distributed generation developers directly impacted by the LCH.</p> | <p>A telephone survey will be conducted by an external agency before and after the project (12/2010 and 02/2015 respectively). During the project we will continuously collect and review feedback, which will be formally reviewed at the four lessons learned sessions detailed in the project plan.</p> | <p>As detailed in all six monthly reports, and in Appendix A. Our DG customers directly impacted by the LCH were contacted by an independent telephone survey conducted by Accent. The results showed that we had developed a very strong relationship with our DG customers but highlighted a few opportunities where we have an opportunity to further improve, such as displaying constraint information.</p> | <p>✓</p> |
| <p>The capture of sufficient information to determine the business case for operating active 33kV ring networks using innovative solutions.</p> | <p>Project closure documentation (02/2015) will include a cost benefit analysis for each of the techniques deployed and the combination of all aspects.</p> | <p>Section 8 details the cost benefit analysis for each method and the project based on the learning from the LCH.</p> | <p>✓</p> |
| <p>Disseminate knowledge and evaluate the potential for similar projects throughout the UK.</p> | <p>The project closure documentation will detail the knowledge generated from the design, construction operation and commercial aspects from the LCH before 02/02/2015.</p> <p>The final project report will be shared with DNOs and IDNOs and interested parties along with:</p> <ul style="list-style-type: none"> An internet presence; ENA workshops; Publications; and Appropriate industry conferences; etc. | <p>The project has generated a significant amount of knowledge which has been regularly shared with the wider industry. Section 12 details the learning dissemination that has already been carried out, and the planned future activities.</p> | <p>✓</p> |

Section 6 – Required modifications to the planned approach during the course of the Project

6.1 – Change to the Delivery of the LCH

During the bid stages, the project was designed to Central Networks design philosophies and signed off by key stakeholders from around the business. The agreed project construction would have been managed by the New Connections division of Central Networks using external service providers to conduct the work on site. This would result in the project's construction activities being undertaken outside of the main DNO business delivery teams.

After kicking off the project with senior stakeholders and the delivery team, the project entered a detailed design phase focussing primarily on the Network Enhancements, Ring Network and FACTS device.

The design philosophy of the ring network under Central Networks was largely focussing on modifying the existing network infrastructure to enhance the output.

The purchase of the East and West Midlands areas by PPL, the owners of Western Power distribution, along with the organisational integration to a common Western Power Distribution structure and delivery model, led to a number of fundamental changes to the plan for project delivery.

The design and delivery of the LCH, especially the ring network, was affected by the following factors:

- The New Connections activities were brought back into the main business;
- A few centralised teams covering wide areas were divided into smaller teams covering smaller areas;
- Engineering Design was brought in house. The detailed civil and electrical designs would now be delivered internally;
- Changes to key members of staff, either leaving the business or changing roles within the organisation;
- The reduced reliance on contractors and external service providers especially for core distribution activities;
- Changes to fundamental design philosophies including focusing on building a network suitable for the future; and
- Changes to both design and equipment specifications.

6.2 – Commercial arrangements

The Constraints Analysis tool was continually updated throughout the duration of the project to optimise the operation, improve reliability and reduce the study times. This change in approach was required as at times adding additional generation caused the operation of the tool exceeded 6 hours for an additional generation study. With the improvements, it was possible to half the study times without any hardware changes.

6.3 – Change to the delivery of the Ring Method

After the bid, a technical project review group was established including primary network planning specialists, operational safety, and construction engineers along with representatives from the Policy team. This group reviewed and evaluate the high level design created during the bid stage and make recommendations before moving into detailed design phase.

To create an active ring network the original project design included an additional 4.5 km of new 33kV OHL and the existing normally open point at Trusthorpe being closed. This would create a network ring as shown in Figure 22. This new OHL in combination with the active ring network will create an increase in the potential capacity to connect generation.



Figure 22 – Original Ring network design with the new OHL– 2 Radial Feeders

This was always a risk as it required additional wayleaves to be granted and new permissions. Because of this, a number of alternative designs were further explored, with the intention of having alternative network layouts as a fall-back position in case the new OHL could not be constructed. A process was agreed with the technical design group for what needed to be completed before the final design could be passed over to the construction team. These included detailed technical studies, including harmonic network analysis and TRV study (transient recovery voltage). Due to the extreme complexity of these studies, we approached a number of external organisations with the specialist skills to complete the detailed analysis.

We found the wayleave process became increasingly difficult due to local opposition, largely linked to possible new wind farms. After engaging with local landowners it became clear that the proposal to build the new OHL was unfeasible. Although further steps could have been taken to secure permissions (compulsory wayleaves etc.), these were deemed inappropriate for an ahead-of-need investment or a LCH demonstration project.

In June 2012 it became clear that we would not be able to secure necessary permissions to build the new OHL and the project required a change request. The change request replaced the need for new OHL with an alternative construction and protection scheme at Chapel St Leonards and Ingoldmells. In addition, the time taken to gain internal agreement for the alternative design was extended due to changes in roles for a number of key stakeholders as the business transitioned to the WPD structure and delivery model.

Subsequently an alternative network layout was developed that maximised the potential operational capacity of the existing assets. While this did not adversely affect the majority of elements of the project, it has had a significant bearing on the design of the active ring network, and resulted in a redesign of the network layout.

The technical issues preventing the projects from progressing to detailed design were overcome with the input from the technical project review group and a change request with a design justification report created for the new design. The project and change request was independently audited by DNV Kema to show the project would still deliver the required learning. A number of alternative designs were explored and evaluated before the project issued a formal change request to Ofgem, sent 28th May 2013. This was approved by the Authority in August 2013.

The design justification report and change request have been included in Appendix O. Figure 10 shows the project plan for the delivery of the Ring Network.

6.4 – Network Enhancements

Feedback from arable land owners revealed they were not willing to accept shorter span lengths, that is, closer spacing of OHL poles. The 33kV circuits being replaced were constructed in the 1950's and have a typical span length of 150-160m. Following WPD standard 43-40 design philosophy, a 150mm² single wood pole design would have an average span length of approximately 120m, whilst a 300mm² single wood pole design would have an average span length of approximately 85m. The feedback from landowners led to the designing of a new H pole construction with an equivalent span of 160m for similar future scenarios. The pole positions of the OHLs were discussed with landowners and residents so as to not obstruct farming practices and to reduce the impact on visual amenity. The necessary wayleave permissions were granted on that basis.

6.5 – Dynamic Line Ratings

The delivered Dynamic Line Ratings approach followed the planned approach.

6.6 – Dynamic Voltage Control

The delivered Dynamic Voltage Control approach largely followed the planned approach. However, due to a limitation of the D20 RTU being able to send analogue signals, a GE D400 RTU was procured and installed to support Dynamic Voltage Control.

6.7 – Flexible AC Transmission Systems

The delivered FACTS approach followed the planned approach. The electrical size of the DStatcom exceeded the rating in the bid due to the units being delivered in modular sizes. This further increases the capability of the DStatcom to control the network voltage.

6.8 – Telecommunications

Due to a UK shortage of the material for the optical fibre exterior jacket, the fibre installer for the project used an alternative product to that originally offered. This caused issues in the installation phase as the material was less pliable than the normal jacket. During the installation process the fibres became damaged and failed. This required the manufacturer to re-wrap approximately 10km at their own expense. The lessons learnt from this installation were captured in the Lessons Learnt log and processes have been put in place to reduce the risk of the same issue occurring, and identifying it early if it does ever occur again. The subsequent re-wrapped circuit showed all 96 fibres passed the tests.

The use of the optimised protection variant (OPV) Mimo Max equipment was considered for the project, however the bandwidth was significantly lower than microwave links, a much higher latency meant several links could not be used in series whilst still maintaining a sub 6ms response required for the current 33kV differential protection.

Section 7 – Significant variance in expected costs

| | Total Budget £k | Total Spend £k | Variance | Variance % |
|---|--------------------|-------------------|------------|--------------------|
| Box 6 – Labour | 549 | 604 | 56 | 9% |
| WPD Project Management | 235 | 239 | 4 | 2% |
| Create a 33kV active network ring – Skegness | 17 | 18 | 2 | 9% |
| Create a 33kV active network ring – Alford | 36 | 42 | 6 | 15% ¹ |
| Create a 33kV active network ring – Ingoldmells | 83 | 87 | 4 | 5% |
| Create a 33kV active network ring – Chapel St Leonards | 91 | 130 | 39 | 30% ¹ |
| Create a 33kV active network ring – Trusthorpe | 82 | 81 | 0 | -1% |
| Create a 33kV active network ring – Bambers | 5 | 6 | 1 | 18% ¹ |
| Box 7 – Equipment | 1510 | 1675 | 165 | 10% |
| Dynamic Voltage Control – Development + Maintenance of ENMAC and SCADA systems, Voltage control algorithm including Training and site AVC modifications | 42 | 51 | 9 | 17% ² |
| Flexible Alternating Current Transmission system (FACTS) – procurement of Devices | 575 | 571 | -4 | -1% |
| Create a 33kV active network ring – Skegness includes: new CTs, Protection, 33kV cable and small wiring | 48 | 52 | 5 | 9% |
| Create a 33kV active network ring – Alford includes: new CTs, protection, 1250A busbar, VT, 36kV Breaker, 33kV cable & small wiring | 102 | 121 | 18 | 15% ¹ |
| Create a 33kV active network ring – Ingoldmells includes: new CTs, protection, VT, earth electrode, 36kV Breaker, 1250a busbar, 3ph insulators, 33kV cable & small wiring | 236 | 278 | 42 | 15% ¹ |
| Create a 33kV active network ring – Chapel St Leonards includes: new CTs, protection, VT, RMU, 1250a busbar, 33kV cable & small wiring | 260 | 325 | 66 | 20% ¹ |
| Create a 33kV active network ring – Trusthorpe includes: new CTs, protection, Incoming Transformer, 3/7 new switchboard, earth electrode, 33kV cable & small wiring | 233 | 255 | 23 | 9% |
| Create a 33kV active network ring – Bambers includes: new CTs, protection & small wiring | 14 | 22 | 7 | 33% ³ |
| Box 8 – Contractors | 357 | 283 | -74 | -26% |
| Engineering Design & Surveys | 106 | 107 | 0 | 0% |
| Enhancing planned network alterations – 33kV OHL asset rebuilds as 300HDA instead of 150 ASCR | 80 | 78 | -2 | -2% |
| Innovative Commercial Arrangements – Workshop, Lawyers, data flows, network configuring with generators | 70 | 27 | -43 | -158% ⁴ |
| Development + Maintain of ENMAC and SCADA systems, Voltage control algorithm including Training and site AVC modifications | 21 | 21 | 0 | -2% |
| Dynamic Systems Ratings – Future Design standard 1) fibre over existing lines | 10 | 0 | -10 | -100% ⁵ |
| Dynamic Systems Ratings – Future Design standard 2) fibre over new lines | 10 | 0 | -10 | -100% ⁵ |
| Dynamic Systems Ratings – Future Design standard 3) radio or microwave links | 10 | 0 | -10 | -100% ⁵ |
| Flexible Alternating Current Transmission system (FACTS) – provision of foundations | 50 | 50 | 0 | 1% |

LOW CARBON HUB

LCN FUND PROJECT CLOSE DOWN REPORT

| | | | | |
|--|-------------|-------------|------------|---------------------|
| Box 10 – IT Costs (inc Telecommunications) | 872 | 973 | 101 | 10% |
| Telecommunications Design | 25 | 81 | 56 | 69% ⁶ |
| Graphical Interface of data received, Development + Maintenance of ENMAC and SCADA systems, Voltage control algorithm including Training | 60 | 43 | -17 | -38% ⁷ |
| Site AVC modifications. | 21 | 21 | 0 | -2 |
| Dynamic System Ratings | 50 | 0 | -50 | 100% ⁵ |
| Fibre to OHLs | 458 | 480 | 21 | 4% |
| Skegness to Alford Line (UG Fibre) | 20 | 41 | 21 | 51% ⁶ |
| Skegness | 20 | 40 | 20 | 51% ⁶ |
| Alford | 17 | 25 | 8 | 34% ⁶ |
| Ingoldmells | 48 | 69 | 21 | 31% ⁶ |
| Chapel St Leonards | 48 | 70 | 22 | 32% ⁶ |
| Trusthorpe | 48 | 48 | 1 | 1% |
| Bambers | 19 | 23 | 5 | 21% ⁶ |
| Skegness Comms | 32 | 32 | 0 | 1% |
| Skegness Comms | 9 | 0 | -9 | 100% ⁸ |
| Box 10 – IT Contingency | 129 | 132 | 2 | 2% |
| Combined Project | 14 | 27 | 12 | 46% ⁹ |
| Enhancing Planned network alterations | 3 | 0 | -3 | 100% ¹⁰ |
| New commercial agreements with DG customers with increased capabilities | 5 | 16 | 11 | 68% ⁹ |
| Dynamic voltage control | 3 | 0 | -3 | 100% ¹⁰ |
| Dynamic system ratings | 22 | 0 | -22 | 100% ¹⁰ |
| Flexible Alternating Current Transmission system (FACTs) | 25 | 69 | 44 | 64% ¹¹ |
| Create a 33kV active network ring | 57 | 20 | -37 | -186% ¹² |
| Totals | 3417 | 3667 | 250 | 7% |

¹ As detailed in six monthly reports, Section 6, the requirement to change to the planning approach added additional costs due to a change in scope and a truncated delivery programme. The CBA as described in Section 8 has also been updated accordingly.

² As this method developed, there was a requirement for a D400 RTU capable of sending analogue outputs to the AVC relays due to a limitation with the existing D20 RTU.

³ Variance in the scope of works (reconfiguring of transducers) and using external resource has resulted in increased costs

⁴ As this project developed, it was possible to deliver this section for less than the project budget. Some costs were re apportioned where they had been incorrectly reported in previous 6 monthly reports.

⁵ This activity was conducted by Western Power Distribution internally and accounted for in Project Management.

⁶ Variance in the scope of works (installing 96 fibres instead of 24) and poor ground conditions have resulted in increased design and delivery costs.

⁷ As this project developed, it was possible to deliver this section for less than the project budget.

⁸ This communications link was no longer required due to wider changes to the WPD SCADA network as the project developed.

⁹ Costs associated with delivering the method but out of scope of the original design.

¹⁰ Contingency was required in these sections.

¹¹ Increased civil costs associated with poor ground conditions.

¹² Costs and descriptions have been included in boxes 7 & 8.

Funding the Active Network Management scheme was outside of the scope of this project. The ANM was purchased by the project with costs being apportioned to customers as they progress with their connection.

Customer Connection costs recoverable at Feb 2015.

| ANM System Installation Costs included in Crown Scheme | |
|--|--------------------|
| Site A | £75,000.00 |
| Site B | £75,000.00 |
| Site C | £67,800.00 |
| Site D | £88,920.00 |
| Site E | £60,900.00 |
| | £367,620.00 |

Section 8 – Updated Business Case

In overview, the business case for this project remains very strong. We are expecting the DG connection request to continue to increase as the UK transitions to a Lower Carbon Economy. In an increasing number of areas, it will be more difficult to connect these DG due to increasing network voltage and thermal limitations. The effectiveness of certain LCH methods will provide new connections at lower cost than the conventional solutions.

The project also delivers substantial benefits to DG customers by unlocking additional cost effective capacity for new DG. To date, this project has reduced the cost associated with network reinforcement by £42m.

| Description of Direct Benefit | Value of Direct Benefit | | | | Total |
|--|-------------------------|---------|---------|---------|---------------|
| | 2011/12 | 2011/12 | 2013/14 | 2014/15 | |
| DG Incentive Value – including the OAM allowance | | | 40000 | 80000 | 120000 |
| TOTAL | | | | | 120000 |

Table 4 – Re-forecasted Benefits April 2012

8.1 – Commercial arrangements

The majority of the Lincolnshire LCH benefits attributed to a DNO were focussed on the financial benefits to DNOs through the DG incentive value. This was withdrawn at the start of ED1, April 2015. This has been replaced with a new mechanism within ED1 which combines the costs associated with both demand and generation connection costs and provides the business case to seek lower cost alternatives to conventional network reinforcement. Whilst, at the end of the project, the new Alternative Connections are still in planning or construction resulting in connection being later than forecast, the number of accepted connections are much higher than originally forecast. This has accelerated the roll out of ANM across WPD.

The Cost Benefit Analysis of this method is high; the method will be replicated a further 11 times within WPD's network area by 2023, indeed, Corby and Bridgwater have already accepted 119MVA of generation capacity using Alternative Connections.

8.2 – Ring Method

This method was technically successful in reducing network impedance, allowing generation to be connected electrically closer to demand, improving network resilience and improving network availability.

However, the Cost Benefit Analysis of this method is poor. As documented in Section 7, the costs associated with the ring method are high, and the capacity released is relatively modest. As a result of the ring method, an additional 10MVA Alternative Connection has accepted due to the reduction in constraints.

8.3 – Network Enhancements

The project rebuilt 10.1km of OHL with a much larger capacity conductor with a lower impedance. Reducing the impedance of the network reduces both voltage rise and technical losses.

The Cost Benefit Analysis is high; the additional costs have been estimated as £8,000 per km, whilst capacity released is approximately 12MVA of additional headroom. The method has also reduced voltage rise by 24%.

8.4 – Dynamic Line Ratings

This method has demonstrated that the electrical output from a wind farm can be used as a proxy for wind speed in a Conservative Dynamic Line Rating algorithm, however Dynamic Line Rating is less appropriate at 33kV due to the increased risk of sheltering. This is a significant barrier to DLR being used at 33kV to unlock additional generation capacity so the effective business case for this approach is very poor.

8.5 – Dynamic Voltage Control

Dynamic Voltage Control did not demonstrate a cost benefit during this project. However it shouldn't be written off as an approach because there is much potential for it in the future.

8.6 – Flexible AC Transmission Systems

The DStatcom has proven to be very effective at controlling network voltage and reducing losses by balancing reactive power flows. The device could also be used to manage reactive power flows between the distribution network and transmission networks.

The DStatcom is a relatively complex high value item that will likely require long term service plans and access to spare parts. The CBA for DStatcoms is good if installed in the right network areas, however the long term costs of servicing and maintenance should be taken into account when considering their future use.

| Method | Cost (£) | Capacity increase (MVA)* | Comments/Other benefits/disadvantages |
|--------------------------------|-----------------------|--------------------------|--|
| 1. New Commercial Arrangements | ≈£550k | ≈50MV ^{A1} | ¹ Based on East Lincolnshire capacity, other network will vary considerably. Significant benefits to DG developers with reduced network reinforcement costs. |
| 2. 33kV Active Network Ring | ≈£2,000k ² | ≈ 5-8MVA ³ | ² Based on East Lincolnshire network, the costs will vary dependent on design, space, complexity... ³ Very dependent on the location of new generators, the Active Network Ring provides a much greater security of supply and reduction of constraints associated with abnormal network operation. |
| 3. Network Enhancements | ≈£8k/km | ≈12MVA ⁴ | ⁴ Based on 300HDA to the LCH standard without fibre installed being installed instead of 150ACSR. Very dependent on the location of new generators. |
| 4. Dynamic System Ratings | ≈£10k | 0MVA ⁵ | ⁵ Based on the risk of sheltering, DLR has not unlocked any additional capacity. |
| 5. Dynamic Voltage Control 5. | ≈£100k | 0MVA ⁶ | ⁶ DVC requires additional work before Non ANM capacity can be released. DVC will reduce constraints of Alternative Connected Generation with Voltage Rise constraints. |
| 6. FACTS | ≈£775k | ≈15MVA ⁷ | ⁷ Very dependent on the location of new generators and the step change restrictions. |

Table 5 – summary of capital cost benefit analysis (Replication)

*Based on each method being applied individually. If applied together, the capacity increase will not summate. The actual capacity of all techniques will depend on the network characteristics, demands and other generation connections to name a few.

Section 9 – Lessons learnt for future Innovation Projects

The learning associated with the LCH project and each method within it was published in a stand-alone Knowledge Dissemination document, included in Appendix K. The key learning has been summarised in this section described for the individual methods and for the overall project.

9.1 – Commercial arrangements

- When modelling Constrained Connections, there is a balance between the accuracy and the speed at which constraint analysis results are produced. When modelled in one GSP network it is possible to manage both a high degree of accuracy and speed, however the LCH tool has shown that, using the approach taken, it would not be sustainable for more than one BSP or entire network area using desktop computing.
- When creating a nodal analysis software tool, there is a requirement to ensure any version changes of interfacing software do not have a negative affect the software tool. When creating a software tool, the validation testing checks all the operational limits, ensuring any bugs are captured whilst the tool is still in development.
- When the tool is required by the business, the required Service Level Agreements need to be in place to fix any issues or to make an acceptable alternative available in the event of the Software tool not being available.
- When analysing networks for Active Network Management, check all of the unintended consequences have been fully assessed, including that both the ANM kit and constraint analysis software takes into account the network configuration, credible outages and maintenance profiles and the operation of the protection during normal and abnormal network operation, to ensure the network's operation will remain stable.
- For Active Network Management using the SGS approach; One of the key parameters within an ANM system is the setting of suitable limits for each measurement point. These are imposed to constrain and release generation within the ANM scheme whilst ensuring all sections of the network remain within their design and statutory parameters. For the Trim, Trip, Sequential trip and Global trip control generator output for critical network positions,. if settings are too low, DG sites would be constrained off prematurely and the capacity within the network will not all be released. If the settings are too high, the generation could lead to cascade trips and global trips. The DNO requires a methodology and tool to calculate the thresholds, ramp rates and sensitivities for generation under normal and abnormal network operation so they can be sure they know the risks associated with ANM operation and constraint studies.

9.2 – Ring Method

- The LCH design was completed using desktop planning; learning from this project has shown that for a project of this complexity, further design works at the bid stage was required to gain a better understanding of the project requirements. During the delivery stages it was apparent that with the increase in scope and the issues identified on site, the project lacked adequate funds.
- The project aimed to show how the existing network could be altered rather than rebuilt to enhance capacity. With the project delays associated with not receiving permission for the new OHL line, it is now conceived that the use of 33KV switchboards would have been an economical advantageous alternative to an AIS or hybrid AIS solution. They would have reduced network risk due to an offline build, required a shorter construction phase, and the result of a simpler network to operate. Due to the truncated delivery times without a project extension, a GIS only solution would have been selected for both Chapel St Leonards and Ingoldmells. With a delivery timescales over a two year period, an AIS only solution at Ingoldmells would have been the most appropriate solution.
- The delays in the first two years of the project resulted in a truncated period for both designs and delivery; this made the construction phase more difficult. If looking to replicate this technique again in a new area, it would be sensible to allow at a minimum of 3 months for design works per substation and 6 – 12 months for construction per substation depending on the length of the works.

When meshing radially designed and protected substation circuits, additional circuit breakers and protection equipment is required. The following factors need to be taken into account:

- The operation substation compound is often sized for the existing equipment. Adding additional network equipment can require an extension of the existing operation compound.
- Maintaining safe equipment spacing between assets can prevent some designs from being realised without significant rebuilding activities. This could not be achieved within the project budget, timescales or the original project ethos.
- Delivery of complex construction activates as an online build can often not be achieved without an unacceptable compromise of the safety of staff during construction activities.
- Using a hybrid of existing air insulated assets and new gas insulated switchboards connected with cables can lead to the operation of sites being more complex to operate.

- The inclusion of Ingoldmells primary substation and the associated circuits has significantly increased the number permutations for both normal and abnormal running arrangements leading to delays in selecting an acceptable LCH design that can be adequately protected.
- Ensuring that future construction activities at primary substations are not made more complex or expensive by work completed under this project.
- The design of an active ring using sites with additional circuits retrofitted to them is more complex due to additional space constraints when trying to connect new switchgear.
- Issues include not having the required number, type or accuracy current and voltage transformers in the right locations. Space constraints within existing substations – how to make the most from the existing assets.
- Requirement to make the network better after completing works can rule out a large number of options.

9.3 – Network Enhancements

- New wayleaves were required for replacing the existing circuits. These can be secured, however the landowners in this area are resistant to accepting replacement lines with shorted span lengths.
- WPD's OHL design software erroneously models conductor sag based on tension. Adding fibre wrap to an OHL apparently increases the weight rather than the tension. The resultant design based on tension is more conservative but will ensure that statutory clearances are maintained. This required some existing poles to be increased to take into account the new sag profile.
- A new policy was required to cater for the earthing design of Splicing Canisters and the application of temporary earths to an OHL with SkyWrap. Splice canisters should be included in key locations where the OHL may be broken to allow other works to be carried out.
- In future, optical fibre testing would be carried out immediately after the fibre installation. Any issues with the installation could then be identified and fixed quickly, avoiding the issues associated with having to re negotiate further access to landowners' fields.

9.4 – Dynamic Line Ratings

Future Dynamic Line Ratings projects will need to understand both the risk and consequences of sheltering occurring on an OHL before the method can be applied. The effect of sheltering that would have occurred before the OHL was relocated would have prevented any increases in capacity being applied based on the other conservative factors.

9.5 – Dynamic Voltage Control

Dynamic Voltage Control requires future work before it will be ready for wider area deployment without Active Network Management. The LCH has proven the concept and how it could be incorporated into an ANM enabled area.

Networks' voltage profiles can be optimised by using centralised network intelligence. A control algorithm can be located within a NMS with remote target voltages applied to an AVC using an algorithm to determine if the network voltage can be safely optimised taking into account both the demand and generation. Further work is required to make this a more robust and failsafe method for roll out across a wide area to unlock additional generation connections. Specifically, the method must account for communications and control system outages before capacity can unlock new DG capacity.

Transferring an AVC relay across to DNP3 control will unlock additional functionality in the relay; however this requires numerous changes across the business outside of a trial. An AVC relay can be cost effectively be used to provide a steady state voltage measurement where there isn't a VT.

A DVC algorithm needs to be flexible enough for changes in network connections and needs to operate without regular intervention of a control engineer.

9.6 – Flexible AC Transmission Systems

The DStatcom is a new technology for the majority of DNOs. A significant amount of learning has been generated from this project. This is detailed in Appendix L and Appendix M. The key aspects when replicating this method include the careful assessment of aspects such as noise, electric and magnetic fields being maintained down to acceptable limits. These issues could be controlled at the tendering stage with the supplier detailing how they will mitigate environmental issues through the design of the device. Future uses of DStatcoms will also need to consider the whole life cost including maintenance, replacement components and losses. These should be taken into account when compare an innovative solution to a conventional network solution.

Section 10 – Project replication

In order to replicate the LCH Project, both physical components and the knowledge provided in the tables below are required for each method. Please contact WPD at wpdinnovation@westernpower.co.uk for further detail relating to any physical component or knowledge requirements.

| Physical Components | Specifications | Products used in Project |
|--|---|--|
| 10.1 – Commercial arrangements | | |
| Alternative Connection Offer letter | <p>The Offer letter must cover all of the aspects within a conventional Section 15 or Section 16 connection. The offer letter must also clearly make the customer aware their connection will be subject to constraints under both normal and abnormal running arrangements, make clear which network assets their connection will be constrained against and the associated one-off and ongoing costs associated with an Alternative Connection.</p> <p>WPD's alternative connection offer letter also includes example constraint studies based on historical network analysis.</p> | WPD Alternative Connection offer letter (See Appendix C) |
| Alternative Connection Agreement | <p>The connection agreement must cover all of the aspects with a conventional agreement. This must also include how the Active Network management will constrain a generator, the equipment boundaries and the requirements the generator must satisfy, such as response rates, in order to maintain an Alternative Connection.</p> | WPD Alternative Connection Agreement (See Appendix D) |
| Constraint Analysis Software | <p>For a network with meshed and radial feeders, nested voltage and current constraints at different voltage levels, a time series nodal analysis constraint analysis software tool is required to model the impact of Alternative Connections.</p> <p>The constraint analysis software must be capable of running time series demand and generation models, representing either the previous or future scenarios. The software must match the operation of an Active Network Management scheme; constraining generation based on the principles of access whilst ensuring the network does not operate outside the design and statutory limits.</p> <p>The tool must provide accurate, repeatable results, identify which network components were causing the constraints, identify the magnitude of overloads or voltage violations and identify reverse power flow through transformers. Full details on the design of the WPD Constraint Analysis tool has been included in Appendix F.</p> | WPD Constraint Analysis tool – created by TNEI. |
| Active Network Management scheme | <p>Procured as per ANM Tender specification – Appendix B. The device must be capable of monitoring key programmed voltage and current thresholds, controlling or constraining generation output within configurable timescales to ensure the distribution network does not operate outside the design and statutory limits.</p> <p>The ANM scheme must operate in a logical, predictable way, constraining and releasing generation following the principles of access.</p> <p>The ANM device must be fail safe, should operate autonomously, but should be able to be overridden or controlled remotely, preferably through a DNO's NMS.</p> | SGS ANM 100 |

LOW CARBON HUB

LCN FUND PROJECT CLOSE DOWN REPORT

10.2 – Ring Method

| | | |
|---|---|---|
| Substation Plant <ul style="list-style-type: none"> • Circuit Breakers • Protection relays • Line Disconnectors • CT • VT • Plinths, multicores, batteries | <p>The plant required for creating an Active Network ring is relatively standard, off the shelf equipment used for both meshed and radial network construction. The equipment is configured in a different manner and used on a rural 33kV network instead of the 132kV network. This equipment must conform with a DNOs equipment specification in terms of steady state and transient voltages, thermal capacity, accuracy etc. and must be used in a way that allows the safe operation of the distribution network.</p> | <p>Siemens NX+ 36kV Schneider GHA 36kV Hawker-Sidley 1250A CB Transmag 36kV VT P543214A4M0570K P544214A4M0570K ITL – 36kV OD 1φ Post CT</p> |
|---|---|---|

10.3 – Network Enhancements

| | | |
|---|---|---|
| Overhear Line Components <ul style="list-style-type: none"> • Low impedance Conductor, • 33kV Insulators, • Cross Arms, • Tall, stout poles • Stays | <p>The plant for the Enhanced OHL component was procured following WPD’s OHL Specifications. The plant required for building Enhanced Overhead Lines is standard, off the shelf equipment used for the construction of OHL.</p> | <p>300mm² Hard Drawn Aluminium conductor</p> |
|---|---|---|

10.4 – Dynamic Line Ratings (DLR)

| | | |
|---|---|-------------------------|
| <p>A DLR algorithm within a NMS</p> | <p>The Dynamic Line Rating algorithm must take into account environmental factors such as wind speed, wind direction, ambient temperature, and solar irradiance. The algorithm should also take into account the accuracy of the information being used in the calculation, the thermal constant of the circuits and the levels of headroom being selected for the project.</p> | <p>GE DLR algorithm</p> |
| <p>Wind Speed Algorithm Real time electrical output from a Wind Farm and algorithm for calculating wind speed from Electrical output.</p> | <p>Written within PowerON Fusion, configurable for different wind farms turbine outputs. Configurable with different safety factors included, interfacing directly with the Dynamic Line Rating algorithm.</p> | <p>N/A</p> |

10.5 – Dynamic Voltage Control (DVC)

| | | |
|--|--|---------------------------|
| <p>Remote configurable Automatic Voltage Control relay</p> | <p>The device must provide the equivalent functionality of a standard Automatic Voltage Control relay, operating in both automatic and manual modes, regulating network voltage through a tap changer based on local V & I measurements at the substation.</p> <p>The device must also have secure communications functionality and be capable of amending the target voltage.</p> | <p>SuperTAPP n+</p> |
| <p>Remote Telecontrol Unit</p> | <p>Suitable for DNP3, sending and receiving Analogue values, digital values, alarms & indications. Complying with WPD’s standard RTU policies.</p> | <p>GE D400 GE D20</p> |
| <p>A DVC Algorithm within a NMS</p> | <p>A time and sensitivity configurable algorithm, autonomously reviewing network connectivity, voltage and current values, checking against pre-defined limits, capable of determining a more optimum target voltage.</p> | <p>N/A</p> |

| | | |
|---|---|---------------|
| Middle management data acquisition system | Communicable with a 3rd party device via GPRS sim card, capturing analogue and digital data, hosting a scripted Python algorithm, saving a new analogue system. | Nortech iHost |
|---|---|---------------|

10.6 – Flexible AC Transmission Systems

| | | |
|---|--|--|
| A FACTS device and associated transformer | DStatcom – Compliant with WPD EE200 Engineering Specification, exceeding 2.7MVAR electrical output at 33kV. DStatcom Power Transformer Parameters – Rating 5000 kVA, H.V Volts 33000 Rated I 50.0 Amps, H.V Tappings +/-2.5 +/-5.0%, L.V1 Volts 480 Rated I 3007.0 Amps, L.V2 Volts 480 Rated I 3007.0 Amps, cooling ONAN, phases 3, frequency 50, vector group Dyn1yn1, insulation Class A, enclosure rating IP66. | S&C Purewave DStatcom (3.75MVAR) Ultra Electronics 5MVA power transformer |
|---|--|--|

10.7 – Telecommunications

| | | |
|--|--|---|
| <p>Optical Fibre Wrap</p> <ul style="list-style-type: none"> • Multiplexers <p>Microwave Circuits</p> <ul style="list-style-type: none"> • Microwave Dishes • Lattice Tower • Multiplexers | <p>The total communication latency between protection relays was specified to comply with ENA Category 1 communications with a latency of less than 6mS under both normal and abnormal scenarios.</p> <p>Fibres shall conform to the requirements of ITU-T-G.652 and IEC 793. The average fibre attenuation coefficient shall not be greater than 0.38 db/km at wavelengths between 1285nm and 1330 nm in all cases. Maximum individual fibre attenuation shall not exceed 0.25 db /km and shall be identified for each drum (or equivalent values for 1550nm).</p> <p>Any microwave towers should be installed sufficiently high to provide line of sight between both towers.</p> <p>The lattice tower and foundation design required for each site should accommodate the total potential number of microwave dishes which could be installed on the site in the required environmental conditions such as wind loading and the soil conditions.</p> <p>The communication channels will need to be designed and specified for 64Kbps bandwidth, the LCH microwave system has been designed to accommodate a combined 2Mbps per link.</p> <p>Each location will require a multiplexer, routers, power supplies, and interface cards to link in with the protection circuits.</p> | <p>SkyWrap Birdshot Phase SW-96HM4</p> <p>Pasolink Neo 1+1 System microwave Link</p> <p>SLP2& SLP3 15m microwave towers.</p> <ul style="list-style-type: none"> • CXR QX3440 multiplexer • CXR CPU with E1 clock • CXR 48VDC Power for QX3440 150W • CXR Bridge router interface with 8 port switch • CXR 3 E1 RJ45 75ohms BNC card • CXR QX3440 4 E1 Fibre Optic dual fibre • CXR QX3440 4 channel optical fibre link C37.94 interface card |
|--|--|---|

10.8 – Commercial arrangements

| Knowledge (Subject) | Application | Methodology |
|---|--------------------------------|---|
| Network Modelling & Data analysis | Alternative Connection Studies | Understanding how the Distribution Network will operate under normal and abnormal network conditions with constrained connections |
| Power Engineering & protection analysis | Active Network Management | Configuring an ANM scheme and constraints limits, and understand the impact on network protection |

10.9 – Ring Method

| | | |
|--------------------------------|-----------------------------------|--|
| Power System Analysis & Design | Designing an Active Network Ring | Designing in additional plant to the existing network, Steady State and Transient analysis of the design |
| Protection Design | Protecting an Active Network Ring | Protection configuration & discrimination under normal and abnormal running arrangements |
| Network Construction | Meshing network | Constructing additional plant into existing substations |

10.10 – Network Enhancements

| | | |
|------------------------|--------------------------------|---|
| Power System Analysis | Specifying OHL characteristics | Planning network amendments and the impact under normal and abnormal running arrangements |
| Mechanical Engineering | Physical OHL design | Designing an enhanced OHL which is more suitable for the future |

10.11 – Dynamic Line Ratings (DLR)

| | | |
|----------------------|--------------------|---|
| Modelling | Wind speed proxy | Using Electrical output to calculate wind speed |
| Software Engineering | Writing algorithms | Creating Dynamic Line Ratings using electrical output |

10.12 – Dynamic Voltage Control (DVC)

| | | |
|-----------------------|--------------------------------|---|
| Power System Analysis | Analysing Voltage optimisation | Analysing Key voltage points and voltage profiles under normal and abnormal operation |
| Engineering Design | AVC control | Designing and installing an advanced control system for amending system voltages |
| Software Engineering | Writing algorithms | Creating Dynamic Voltage Control Algorithm within an NMS |

10.12 – Dynamic Voltage Control (DVC)

| | | |
|-----------------------|--------------------------------|--|
| Power System Analysis | FACTS specification and design | Specifying and optimising FACTS output |
|-----------------------|--------------------------------|--|

10.14 – Telecommunications

| | | |
|----------------------------------|---------------------------|---|
| Telecommunication Network design | Protection Communications | Designing and building a telecommunications network |
|----------------------------------|---------------------------|---|

No relevant foreground IP has been identified through the LCH project.

Section 11 – Planned implementation

This section details how we are planning on implementing the LCH methods to unlock additional DG capacity. Where a method is not ready to be implemented, the reasons and the areas that require further work have been documented.

11.1 – Commercial arrangements

The learning from the LCH has shown there is both a significant appetite and opportunities to further implement Alternative Connections across the wider areas to cost effectively unlock further generation capacity. The implementation is most suitable to areas where there are already widespread network constraints, significant demand for further generation connections and diversity between demand and generation profiles.

Within Western Power Distribution, Alternative Connections are not considered a Business as Usual activity. East Lincolnshire was the first ANM implementation and there has been a commitment to implement Alternative Connections across all four WPD licence areas with 11 new zones opened by 2023. Each will use the Alternative Commercial agreements developed as part of this project. Further information is available on www.westernpower.co.uk/connections.aspx.

As part of the internal implementation, ANM policies and Standard Techniques have been written for offering alternative connections as a BaU process, WPD's 200+ planners have been trained how to offer alternative connection offers, and we have changed its core database to facilitate the alternative connections.

WPD is developing a core constraints analysis tool that will eventually be used for calculating constraints in all ANM areas using the learning generated from this project (as detailed in Constraint Analysis tools). The future Constraints Analysis tool will focus on solving the issues with speed and robustness identified in this project. It is expected that the Alternative Connections will continue to evolve taking into account the learning from both East Lincolnshire and the future roll out of ANM by both WPD and other UK DNOs.

Areas which require further work

- When a customer does not want an Active Network Management connection but is within an ANM zone, a common consensus is required across all DNOs as to how new standard firm or non-firm connections should be designed in an ANM controlled area. There is a requirement to offer the minimum cost scheme and to ensure the new connection does not have a negative impact on any other Alternative Connections.
- Protection philosophies and settings have historically been designed around a demand driven network. Further studies and analysis will be required when ANM is rolled out to each new area to ensure that the network protection philosophies, settings and the control of Alternative Connections remain compatible.
- Distribution Network Operators will require a robust Constraint Analysis Software tool when looking at rolling out Active Network Management to more complex networks.

11.2 – Ring Method

This technique has shown to increase network capacity and improve network security, but it is very dependent on the existing network infrastructure. A simple meshing operating using PMAR could be achieved if the resultant power flows are maintained within the equipment ratings and the voltage and current transformers required for the protection scheme can be incorporated into the network. This was not feasible for East Lincolnshire network.

The process of re designing an existing radial overcurrent protected network technique does take a considerable amount of time and effort owing to the complex design works, long lead time items and the requirement for network outages. This means the techniques are more likely to be used for a long term investment ahead of need to increase network capacity rather than responding to a specific generation connection.

The CBA of the Active Network Ring as detailed in Section 8 means there are often quicker, more cost effective methods of unlocking additional capacity which should be applied first, such as Active Network Management or Network Enhancements, and this may limit the potential for replications across GB.

Future replications of the Ring method across Western Power Distribution would be made on a case by case basis, driven by it being the most appropriate method. It is likely it would involve more offline rebuilds rather than modifying an existing network to enhance capacity.

11.3 – Network Enhancements

In areas where there are clear indications Distributed Generation will be connected, the enhancement of assets should be considered as assets are due to be replacement. This may include installing a lower capacity circuit or a circuit designed for fibre to be retrofitted at a later stage.

When a network has Active Network Management applied, the circuit utilisation is likely to increase. The replacement of assets with a lower impedance and large capacity will both reduce the constraints seen by DG customers and reduce network losses. The design and build costs associated with enhancing OHL's has been shown to be relatively modest. It is proposed that any uplift in costs will have a Cost Apportionment factor applied, CAFFED, for up to 5 years after construction.

11.4 – Dynamic Line Ratings

Dynamic line ratings of 33kV OHLs are most likely to be replicated in rural locations where high levels of generation are causing thermal constraints. Dynamic Line Ratings can be used to increase the capacity of the line under certain conditions, however the risk and consequence of sheltering must be considered on a circuit by circuit basis. Due to the risk of sheltering there are no current plans for WPD to roll out Dynamic Line Ratings for 33kV circuits.

11.5 – Dynamic Voltage Control

The LCH has shown there are substantial opportunities to further optimise AVC target voltage settings using remote measurement data and an algorithm to review the voltage profiles and power flows across the network. The technique has the highest potential for replication in voltage limited networks where there is a significant difference between maximum and minimum demands, where there are different demand profiles across the network, when the feeders are of a similar length, have similar voltage profiles and large levels of intermittent generation connected.

The use of VVT can be used to provide a cost effective steady state measurement where a SuperTapp N+ relay or other suitable relay is in place. A planned upgrade of the SuperTAPP n+ AVC will be released in late 2015; this relay will have this functionality to calculate VVT locally recovering data over SCADA. This will be implemented into WPD's NMS where appropriate.

The solution requires further work to find a solution that will unlock capacity for both firm and non-firm generation connections. This will require DVC to optimise the network in the event the network is operating abnormally or if the communications are not available to unlock DG capacity the relay cannot default to the nominal settings.

The use of DNP3 and other communications protocols for AVC relays control is being considered for rollout, however this requires further longer term testing and support training in place across the entire licence area before being ready for rollout.

11.6 – Flexible AC Transmission Systems

There is a significant opportunity to replicate the DStatcom installation in locations where either steady state or transient voltage control is an issue. The project team have supported Scottish Power and shared learning to help them assess where DStatcom could be used to solve network issues.

In the future it is likely that the DStatcom will be used for a number of purposes at different times, including voltage stability, reducing network losses and controlling the flow or reactive power between the DNO and TNO, helping the DNO to comply with the new ENTSO-e regulations. The scale of their future use will depend on further generation connections, steady state and transient voltage restrictions in both the distribution and transmission systems and a reduction in the Capital and operational costs. Their use will be driven by a CBA.

There is a requirement for the design of a Statcom to evolve to make them more suitable for inclusion into a DNO substation, especially when they are being installed in close proximity to customers where the audible noise will be an issue. There is also a requirement for time series analysis in software tools to better support the selection of target voltage and slope setting selection and when it is most appropriate to change these values.

11.7 – Telecommunications

The learning from the LCH has shown that both optical fibre wrap on 33kV circuits and microwave circuits are suitable for future communications links, further work is required to assess the long term performance of the microwave communication links to ascertain if they should be used in other locations as the primary current differential communications link. The current high cost associated with installing fibre on wood pole is likely to prevent its extensive use across the rest of GB.

Section 12 – Learning dissemination

Learning has been shared at regular intervals through the project, eight 6-monthly reports have been written formally sharing learning when it has occurred. Four specific method reports have been published; newsletters have been used to provide general progress updates at key points throughout the project. Three project specific dissemination events have been held for the wider industry and DNOs, several press and magazine articles have been written, the project has been disseminated learning at numerous industry wider conferences and the project has disseminated learning directly to other DNOs in 1 to 1 meetings at their offices.

As outlined in our Stakeholder Communications Plan, a workshop was held on the 15th February 2011 in Skegness for DG developers to outline the project and gauge interest in hub type connections. This was well attended by 11 different developers ranging from local landowners to large multinationals. The LCH was very positively received with the concept meeting both technical and commercial approval. A follow up survey was conducted by an independent organisation to gauge the level of success for the workshop. As a direct result of the workshop a number of connection enquiries to the LCH were received, including the reworking of an existing traditional connection design.

Early learning from the project was shared at the ENA LCNF conference in Gateshead in July 2011. The project was also presented at a number of other events including ACI Smart Grid: Vision, Strategy Implementation conference in London 29th March 2011, the CE Smart Customer Response Trials workshop 25th May 2011 and The Realisation of the Future Smart Grid conference 15th June 2011.

On 6th June 2013 the project was presented to over 90 local authority planners across the East Midlands region at the request of the Head of the Central Lincolnshire Joint Planning Unit. The presentation included details of the Lincolnshire LCH as well as the challenges and opportunities that Western Power experienced.

An innovation connections workshop was held on June 13th 2013 at Pegasus Business Park hosted by WPD and Engage consulting. A selection of people from the DG community were invited including key stakeholders from DG trade associations, DG Developers with recent connections the East Midlands and DG developers that expressed an interest in innovative commercial connections at our business plan workshops. 10 people from 8 companies attended. We introduced the LCH, explained how DNOs planned networks with DG connections under the fit and forget methodology and how if DNOs could offer alternative connections it could allow developers to select an alternative connection over a traditional connection.

The options for alternative connections including offering reactive power support, constrained outputs and trading constraints were discussed. The feedback supported the on-going development of the alternative commercial arrangement developed as part of the LCH. Alternative connections would require a DG developer to accept a non-firm connection to the grid, the amount of interventions required by a DG site will be dependent on where they connect to the network and the number and location of other connections. The amount of information a DG developer would require when accepting a constrained connection instead of traditional network reinforcement.

The feedback from the workshop, led to a consultation document being issued and published on the WPD website. The workshop and consultation concluded that a Last In, First Off “LIFO” constraints methodology was the most appropriate and fairest solution for customers wanting to connect to the Lincolnshire LCH. The charging methodology for the Lincolnshire LCH is based upon the customer only funding the constraint scheme, not any upstream reinforcement. A limitation of this is that overall constraints on the network remain unfunded, ultimately limiting the number of connections that can be made on the distribution network before constraints become uneconomical to overcome.

WPD’s Generation connection offer letter and Connection Arrangements have been amended to create an “Alternative Connection Offer” for constrained contracts. This will be offered to generation developers in the LCH zone alongside WPD’s standard connection offer. The alternative connection documentation was disseminated as part of the consultation and has now been finalised and is being sent to DG developers requesting constrained connections to the Skegness Grid substation at all voltage levels and other select WPD areas. Customers have the ability to opt out of receiving a conventional connection agreement; however the ENA G59 formal connection application must be submitted.

A press release was released in September 2013 disseminating the updates on the progress for the Lincolnshire LCH to the wider industry. The intention was to target trade magazines to also encourage further connections to the LCH to further test the methods being demonstrated.

A dissemination event on Thursday 3rd October 2013 at the East Midlands Hilton provided a general overview of the LCH techniques and the progress of each technique. The detailed aspects of alternative commercial arrangements and constraints estimation were disseminated to a wide ranging audience; 70 people attended, including DNOs, suppliers, manufacturers, trade bodies and generation developers.

LOW CARBON HUB LCN FUND PROJECT CLOSE DOWN REPORT

The LCH techniques were presented on at the Solar Trade Event on 8th October 2013 to over 150 developers. The aim of the event was to share how DNOs are trialling new ways to increase the utilisation of the network.

The development of the LCH was disseminated on at the LCNF conference in Brighton in November 2013 under the integration of DG into the network and the installation and operation of Active Network Management schemes.

Following on from a request and subsequent dissemination of FACTs learning to Scottish power in May 2014 A Flexible AC Transmission System devices (FACTs) dissemination event was held in Louth, Lincolnshire on 24th July 2014. All DNOs were invited to attend the workshop; representatives from four attended. The event provided a detailed overview of FACTs, a description of the relevance to Distribution Network Operators and a copy of all the WPD policies. The lessons learnt from the installation at Trusthorpe Primary substation, and how these lessons could be acted upon to make the FACTs device a solution a DNO could use as an alternative to conventional network reinforcement, were also shared.

A 'Balancing Generation and Demand' dissemination event was held on 20th November 2014. Over 100 people from across the industry attended the event where, learning from all WPD projects on three core areas was disseminated. The learning generated from the LCH commercial agreements was disseminated through the Alternative Connections agreements section of the event.



Figure 23 – Photograph taken at the Balancing Generation & Demand Dissemination Event on 20th Nov 2015

Additionally, the learning from the project has been shared at a Licence Network Operators event – Deployment of Alternative Connections to Generation Customers in the Midlands, South West and Wales, on 16th September 2014 and again at the LCNI Aberdeen dissemination event, 21/10/14.

A final large dissemination event is planned for 2nd June 2015 at Hallam Conference Centre, London. Separately, however, all DNOs have been offered one to one meetings in their offices to further disseminate WPD's, and their own, learning.

Section 13 – Key Project learning documents

Commercial arrangements

August 2014 Knowledge Capture Document

This document details the method and the knowledge captured when developing Alternative Connection Documents.

<http://www.westernpowerinnovation.co.uk>

Ring Method

1/10/2014 Combined LCH Design

This is a set of technical drawings showing the changes to the network at each of the LCH substations.

<http://www.westernpowerinnovation.co.uk/Document-library/2014/Combined-LCH-Design-Appendix.aspx>

Network Enhancements

24/5/2011 LCH Communications Review

As part of the LCH design a review was undertaken to assess the differing techniques available for adding communications infrastructure to the 33kV network. This document details that work and outlines a number of options for adding optical fibre to overhead lines and also assessing a number of differing radio communications techniques that could be employed.

<http://www.westernpowerinnovation.co.uk/Document-library/2011/LLCH-Communications-Review-v1.aspx>

Flexible AC Transmission Systems

1/7/2014 LCH Facts Technical Report

As part of the key deliverables of the LCH project WPD committed to disseminate the knowledge gained from installing a FACTS device on the network. This technical paper details how voltage can be controlled and ascertains if the device improves quality of supply to demand customers and improves generator network availability.

<http://www.westernpowerinnovation.co.uk/Document-library/2014/LLCH-FACTS-Technical-Report-v1-0.aspx>

1/8/2014 FACTS Dissemination Slide Pack

This presentation was delivered by Philp Bale on 24th July at the FACTS Dissemination Event.

<http://www.westernpowerinnovation.co.uk/Document-library/2014/FACTS-Dissemination-Event-Slide-Pack.aspx>

Whole Projects together

1/6/2011 LCH Leaflet

A leaflet giving an overview of the project.

<http://www.westernpowerinnovation.co.uk/Document-library/2012/WPD-leaflet-Lincs-Low-Carbon-Hub.aspx>

1/6/2011 LCH Progress Report

LCH six monthly report Dec 2010-June 2011

<http://www.westernpowerinnovation.co.uk/Document-library/2011/3-LCH-Project-Progress-Report-June-2011-WPD.aspx>

1/12/2011 LCH Progress Report

LCH six monthly report July 2011-Dec 2011

<http://www.westernpowerinnovation.co.uk/Document-library/2011/4-LCH-Project-Progress-Report-Dec-2011-WPD.aspx>

1/6/2012 LCH Progress Report

LCH six monthly report Jan 2012-June 2012

<http://www.westernpowerinnovation.co.uk/Document-library/2012/5-LCH-Project-Progress-Report-June-2012-v1-0.aspx>

1/12/2012 LCH Progress Report

LCH six monthly report July 2012-Dec 2012

<http://www.westernpowerinnovation.co.uk/Document-library/2013/WPD-PPR-The-Low-Carbon-Hub-December-2012.aspx>

28/5/13 Design Justification

This document is intended to outline the designs that have been considered as part of the project and assessment criteria taken in reaching the final design for construction based on the through life assessment.

<http://www.westernpowerinnovation.co.uk/Document-library/2014/Low-Carbon-Hub-Design-Justification-v2-2.aspx>

10/6/2013 LCH Progress Report

LCH six monthly report Dec 2012-June 2013

http://www.westernpowerinnovation.co.uk/Document-library/2013/PPR_WPD_LINCS_LC_HUB_MAY2013_PUBLIC.aspx

1/7/13 LCH Resubmission

The change request submitted to Ofgem due to a change in project circumstances that necessitated a design modification in the active network ring.

[http://www.westernpowerinnovation.co.uk/Document-library/2014/LCH-re-submission-v1-2-\(Clean-Copy\).aspx](http://www.westernpowerinnovation.co.uk/Document-library/2014/LCH-re-submission-v1-2-(Clean-Copy).aspx)

1/9/13 LCH Newsletter Autumn

LCH Newsletter giving an update of the project.

<http://www.westernpowerinnovation.co.uk/Document-library/2013/10-Autumn-Newsletter.aspx>

16/12/2013 LCH Progress Report

LCH six monthly report July 2013-Dec 2013

<http://www.westernpowerinnovation.co.uk/Document-library/2013/11-LCH-Project-Progress-Report-Nov-2013.aspx>

13/6/2014 LCH Progress Report

LCH six monthly report Dec 2013 –May 2014

<http://www.westernpowerinnovation.co.uk/Document-library/2014/LCH-Project-Progress-Report-May-2014.aspx>

1/8/14 LCH Newsletter Summer

LCH Newsletter giving an update of the project.

<http://www.westernpowerinnovation.co.uk/Document-library/2014/Newsletter-LCH-White-2nd-1-0.aspx>

20/11/2014 WPD Innovation Presentation

A WPD Innovation Dissemination event took place sharing some of the wider Low Carbon initiatives including Alternative Connections and the LCH Project.

<http://www.westernpowerinnovation.co.uk/Document-library/2014/17-WPD-Innovation-Presentation.aspx>

10/12/2014 LCH Progress Report

LCH six monthly report June 2014 –Dec 2014

<http://www.westernpowerinnovation.co.uk/Document-library/2014/Lincs-LCH-Nov-14-PPR-V1-0.aspx>

30/1/2015 LCH Knowledge Dissemination Report

This project report details the knowledge generated from the design, construction, operation and commercial aspects from the Low Carbon Hub.

<http://www.westernpowerinnovation.co.uk/Document-library/2015/LLCH-Knowledge-SDRC-V1.aspx>

A copy of project policies are available by request.

Section 14 – Contact details

Philip Bale
Innovation & Low Carbon Network Engineer
Western Power Distribution
Herald Way
Pegasus Business Park
East Midlands Airport
Castle Donington
DE74 2TU
e-mail: pbale@westernpower.co.uk
telephone: 01332 827448
website: www.westernpowerinnovation.co.uk

| Abbreviation | Term |
|--------------|---|
| ACSR | Aluminium Conductor Steel Reinforced |
| ADDS | All Dielectric Self Supporting Cable |
| AIS | Air Insulated Switchgear |
| ANM | Active Network Management |
| AVC | Automatic Voltage Control |
| BAU | Business as Usual |
| BSP | Bulk Supply Point |
| CAF | Cost Apportionment Factor |
| CBA | Cost Benefit Analysis |
| CfDs | Contract for Differences |
| CT | Current Transformer |
| DG | Distributed Generator |
| DLR | Dynamic Line Ratings |
| DNO | Distribution Network Operator |
| DPCR | Distribution Price Control |
| DStatcom | A Distribution Static Compensator |
| DVC | Dynamic Voltage Control |
| ENA | Energy Network Association |
| ENTSO-e | European Network of Transmission System Operators |
| FACTS | Flexible AC Transmission system device |
| FAQ's | Frequently Asked Questions |
| FAT | Factory Acceptance Test |
| FiTS | Feed-in-tariffs |
| FNT | Future Networks Team |
| GB | Great Britain |
| GIS | Gas Insulated Switchgear |
| GoS | Guarantee of Standards |
| GSP | Grid Supply Point |
| HDA | Hard Drawn Aluminium |
| HMI | Human Machine Interface |
| ICP | Independent Connection Provider |
| IFI | Innovation Funding Incentive |
| IR | Information Resources |
| ITT | Invitation to Tender |

LOW CARBON HUB LCN FUND PROJECT CLOSE DOWN REPORT

| | |
|---------|--|
| kV | Kilo Volts |
| LCNF | Low Carbon Network Fund |
| LCNI | Low Carbon Network & Innovation |
| LIFO | Last In First Out |
| LCH | Lincolnshire Low Carbon Hub |
| MCP | Max Conductor Pressure |
| MCT | Max Conductor Tension |
| MCW | Max Conductor Weight |
| MVA | Mega Volt Amperes |
| MWh | Mega Watt hour |
| NMS | Network Management System |
| OHL | Overhead Line |
| OPPC | Optical Phase Conductor |
| OPV | Optimised Protection Variant |
| PID | Project initiation document |
| PMAR | Pole Mounted Auto Re-closer |
| PPL | Pennsylvania Power and Light |
| PSU | Power Supply Unit |
| PV | Photo Voltaic |
| RAID | Risks, Assumption, Issue and Dependency |
| ROCs | Renewable Obligation Certificates |
| RPZ | Registered Power Zone |
| RTU | Remote Telemetry Unit |
| SCADA | Supervisory Control and Data Acquisition |
| SDRC | Successful Delivery Reward Criteria |
| SFRA | Sweep Frequency response analysis |
| SVC | A Static Var Compensator |
| T1 & T2 | Transformer 1 & Transformer 2 |
| TNO | Transmission Network Operator |
| TRL | Technology Readiness Level |
| UHF | Ultra High Frequency |
| VT | Voltage Transformer |
| VVT | Virtual Voltage Transformer |
| WPD | Western Power Distribution |

Western Power Distribution (East Midlands) plc, No2366923
Western Power Distribution (West Midlands) plc, No3600574
Western Power Distribution (South West) plc, No2366894
Western Power Distribution (South Wales) plc No2366985
Registered in England and Wales
Registered Office: Avonbank, Feeder Road, Bristol BS2 0TB

